



**STAA**

STUDENT TRANSPORTATION ASSOCIATION OF ALBERTA



# Bus Driver Competency Program: Training Guide

## TABLE OF CONTENTS

Background .....	1
Conflict Resolution .....	3
Passenger Management.....	11
Effective Communication .....	31
Journey Management .....	45
Driving in Adverse Weather .....	51
Driving in Night/Dark Conditions .....	63
Driving in High Traffic Areas .....	69
Route Hazard Assessments .....	79
Collision Avoidance and Emergencies.....	87

## BACKGROUND

# Bus Driver Competency Program

The Bus Driver Competency Program, aims to provide comprehensive training for both new, intermediate, and seasoned Class 2 or Class 4 school bus drivers.

Offered by employers, this training covers nine key competency areas: Conflict Resolution, Passenger Management, Effective Communication, Journey Management, Winter Conditions Driving, Night/Dark Conditions Driving, High Traffic Areas Driving, Route Hazard Assessments, and Collision Avoidance and Emergencies. School divisions and bus contractors are given the leeway to tailor the delivery of this program to meet drivers' needs.

To complete the Bus Driver Competency Program, drivers must undergo a minimum of 50 hours of training across these competencies within six months. The allocation of these hours among the various competencies is at the discretion of school divisions/bus contractors, allowing them to focus on areas most beneficial for each driver's development. Bus driver trainees and bus driver mentors will be compensated for their time during this training period.



9 Key Areas

50 hrs of Training

Over 6 Months

*“Using mentor drivers with years of experience will provide new and existing drivers with knowledge you can only gain from being a professional bus driver.”*

# How to Use This Guide

This document was created by members of the Student Transportation Association of Alberta (STAA) to help guide bus driver mentors and trainees, to support trainee learning of the nine key competency areas. This training guide may be used by school divisions or bus contractors.

The instructions throughout the guide (in bold italics) are suggestions only, it is entirely up to the driver mentor and trainee to administer this information in a way that works best for them. The resources and videos listed have also been provided as suggestions only. The STAA does not own nor endorse them. For your convenience and to facilitate both pdf and printed usage of this guide, every resource has both linked text and a QR code—hold your smart phone or tablet camera up to the QR code and the link will appear on your device.

We invite you to print this document and insert it into a binder. There are areas for notes throughout the guide, so it may function as a workbook to save important details for later.

Upon completion of this training, notify the school division, at that point they will apply for any available grants. The school division may request documentation as proof of training.

Please direct any questions to [staalberta@outlook.com](mailto:staalberta@outlook.com).

---

## Disclaimer

- This is not a government accredited document.
- This document serves as a guide for transportation providers on how to conduct the Bus Driver Competency Training Program, supported by the Government of Alberta.
- Transportation providers should use this document and any associated links at their own discretion and risk. There is no liability for the individuals or organizations involved in assembling of this document.
- Links to supporting media, such as YouTube, do not grant publication rights. No legal approval for publication has been sought or given.
- Mentors do not need to be licensed driving instructors. Their expertise and experience are leveraged to steer this competency program towards best practices. However, this does not qualify mentors to conduct training that mandates a licensed driving instructor.
- This training mandates a minimum of 50 hours spread over six months. The hours mentioned in this document serve as a suggested reference, recognizing that each specific competency and trainee may require varying levels of instruction. The distribution of these hours is at the discretion of each program provider.

# COMPETENCY 1

# Conflict Resolution

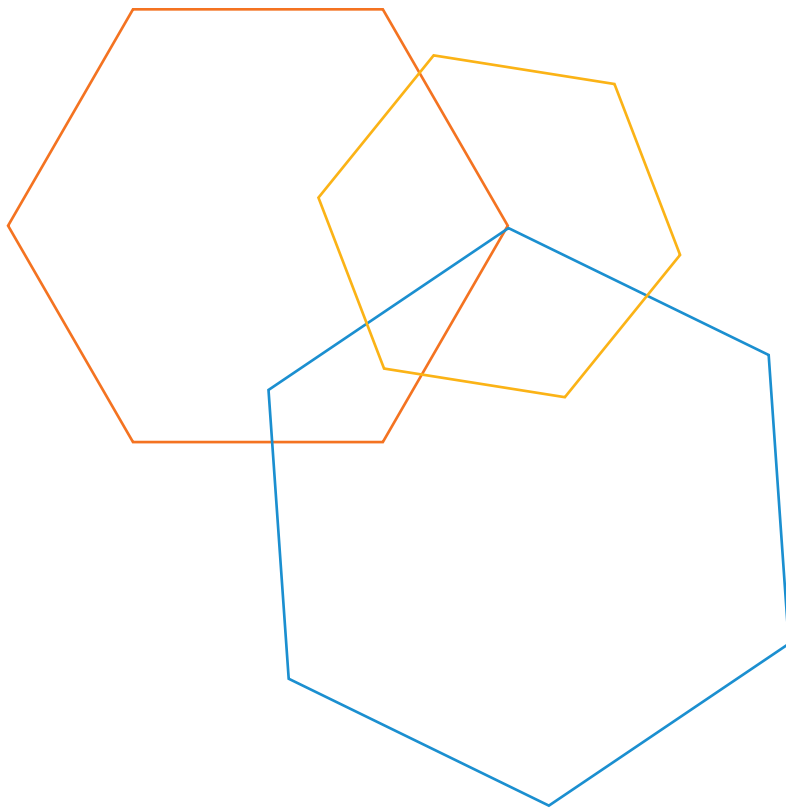



# De-escalation and Resolution Techniques

When encountering a conflict on the school bus, it's important for drivers to maintain calm and composed to de-escalate and move towards a peaceful resolution.

- *Mentor and trainee, review and discuss the following de-escalation and resolution techniques. For more on these techniques, scan the QR code with your mobile device or click on the text to access the additional resources below.*

## Maintain Composure

Stay calm and composed, setting a tone for a peaceful resolution.

## Remain Neutral

Avoid taking sides or getting emotionally involved, ensuring fairness in resolving the conflict.

## Communicate Assertively

Assert yourself respectfully while enforcing rules and boundaries.

## Focus on Listening

Actively listen to the concerns of passengers without interrupting.

## Empathize

Acknowledge the feelings of the individuals involved to show understanding and empathy.

## Use Verbal De-escalation

Use calming words and a soothing tone to defuse tense situations.

## Consider Non-verbal Cues

Body language cues can help calm down agitated individuals.

## Identify the Issues

Identify the root cause of the conflict to address it effectively.

## Brainstorm Solutions

Involve the conflicting parties in finding solutions that satisfy everyone involved.

## Mediate Discussions

Facilitate discussions between conflicting parties, guiding them to reach a resolution together.

## Seek Support



Involve school authorities or supervisors if the conflict is beyond your control.





[Conflict Resolution](#)



[Reducing Bullying](#)



[Yes, You Can De-escalate Anyone, Anytime, Anywhere](#)



[De-escalate Anyone, Anytime: Unplug the Power Struggle \(E-Book\)](#)

# Addressing Disruptive Behaviour

Managing challenging behaviour on a school bus requires a proactive approach, clear communication, consistent reinforcement of rules, and a supportive environment that prioritizes the safety and well-being of all passengers.

- Mentor and trainee, review and discuss the following strategies and responses.*
- Mentor, share school division/bus contractor bus rules with trainee.*

---

## Proactive Strategies

### **Establish and Enforce Rules**

Communicate bus rules and expectations clearly to all passengers before the trip begins and ensure rules are consistently enforced to set expectations for behaviour.

### **Seat Passengers Strategically**

Seat challenging passengers, closer to the driver or away from potential triggers.

### **Build a Buddy System**

Pair challenging passengers with responsible peers to help maintain positive behaviour.

### **Provide Positive Reinforcement**

Acknowledge and praise positive behaviour to encourage desirable conduct.

### **Create a Reward System**

Implement a reward system for good behaviour to incentivize compliance.

---

## Immediate Response

### **Remain Calm**

Stay composed and use a calm voice to address the passengers.

### **Actively Listen**

Listen attentively to concerns before responding.

### **Respond Firmly But Respectfully**

Use assertive language to address disruptive behaviour while maintaining respect.

### **Redirect Attention**

Divert attention by engaging the passenger in a different topic or task.

### **Ensure Consistency and Follow Through**

Clearly communicate consequences for continued disruptive behaviour and ensure consistent enforcement of consequences to reinforce.

Notes: \_\_\_\_\_

\_\_\_\_\_



# Communication and Reporting

Collaboration with the school and parents, along with accurate reporting and confidentiality is key to building trust and creating successful behaviour management strategies.

- Mentors, guide trainee through appropriate collaboration techniques and protocols.*
- Mentor, provide trainee with any school division/bus contractor specific policies, procedures, and forms relevant to this section, such as conduct policies and forms.*

---

## Ongoing Collaboration

### **Communicate Incidents**

Report incidents promptly to school authorities for appropriate follow-up.

### **Seek Guidance**

Collaborate with school counsellors or behaviour specialists for intervention strategies.

### **Create Open Communication**

Reach out to parents to discuss behaviour concerns and strategies for improvement.

### **Connect with Teachers**

Collaborate with teachers to align behaviour management strategies between the school and the bus.

---

## Accurate Reporting

### **Consistently Document Incidents**

Document any conflicts or incidents for reporting purposes, ensuring accuracy and details of the event.

### **Follow Reporting Procedures**

Adhere to the school's reporting procedures for behavioural incidents and follow proper protocol for reporting serious conflicts to the school administration or relevant authorities.

### **Maintain Confidentiality**

Document incidents on individual forms (one per passenger involved). Do not share personal information of the other students involved on the same conduct form, as the form may be shared with parents. The principal will know all students involved.

Notes: \_\_\_\_\_

\_\_\_\_\_

\_\_\_\_\_

# Scenario and Response Training

Bus drivers often encounter situations where behaviours escalate among passengers. When faced with conflict situation, the key is to prioritize safety, maintain composure, and seek support when necessary—while adhering to established safety protocols and regulations. By doing so, bus drivers can effectively manage escalating behaviours while ensuring the safety and well-being of passengers.

- Mentor, simulate the following conflict scenarios or pull videos from the bus as examples, and guide trainee to resolve them using de-escalation and resolution techniques.*
  
- Mentor, after each scenario, facilitate a discussion and offer guidance:*
  - Share what worked well and what could be improved.*
  - Highlight effective strategies used by drivers during mediation.*
  - Offer constructive feedback and guidance on how trainees can intervene calmly and assertively, apply techniques for active listening and empathy, and use strategies for de-escalation and conflict resolution.*
  
- Trainee with guidance from mentor, practice documenting and reporting:*
  - Mentor, have trainee complete school division/bus contractor conduct form.*
  - Mentor (playing the role of parent) and trainee (playing role of bus driver), practice a mock phone call with parents—explaining why the driver wrote the student up.*
  - Mentor, explain to trainee why school administration might not always suspend students from the bus.*

Notes: \_\_\_\_\_

\_\_\_\_\_

\_\_\_\_\_

\_\_\_\_\_

\_\_\_\_\_

\_\_\_\_\_



## SCENARIO 1

# Altercation Between Passengers

### RESPONSE

---

#### **Immediate Assessment**

Quickly assess the situation without diverting attention from driving.

#### **Verbally Intervene**

Use a calm, firm voice to intervene, and separate the passengers involved.

#### **Redirect Attention**

Divert attention by engaging other passengers with a question or task while addressing the situation.

Notes: \_\_\_\_\_

---

---

### ENSURING SAFETY

---

#### **Secure the Bus**

Safely pull over at the nearest stop or safe location.

#### **Call for Assistance**

Contact authorities or school officials for assistance if needed.

#### **Monitor the Situation**

Keep a watchful eye on the situation while waiting for assistance.



## SCENARIO 2

# Disruptive Behaviour from a Passenger

### RESPONSE

---

#### **Maintain Control**

Stay calm and assertive while addressing the disruptive behaviour.

#### **Verbally De-escalate**

Use calming words and a soothing tone to diffuse the situation.

#### **Set Clear Expectations**

Clearly communicate the expected behaviour to the disruptive passenger.

Notes: \_\_\_\_\_

---

---

### ENSURING SAFETY

---

#### **Provide a Safety Protocol Reminder**

Reinforce safety rules and regulations to all passengers.

#### **Seek Support**

Request assistance from school officials or authorities if the behaviour escalates.

#### **Continue Safe Operation**

Ensure safe driving while managing the disruptive behaviour.



### SCENARIO 3

## Verbal Altercation with a Parent or Guardian

#### RESPONSE

---

##### **Remain Professional**

Keep interactions respectful and professional.

##### **Actively Listen**

Listen attentively to the concerns and grievances expressed.

##### **Clarify Boundaries**

Firmly assert boundaries while maintaining a respectful dialogue.

#### ENSURING SAFETY

---

##### **Prioritize Safety**

Ensure the safety of students on the bus without compromising on the route schedule.

##### **Request Assistance**

If the situation escalates, request support from school authorities or law enforcement.

##### **Document**

Document the incident accurately for reporting and record-keeping purposes.

Notes: \_\_\_\_\_

---

---



### SCENARIO 4

## Intoxicated Individual Attempts to Board the Bus

#### RESPONSE

---

##### **Assess Safety**

Assess the situation and prioritize passenger safety.

##### **Politely Deny**

Politely but firmly deny boarding due to safety concerns and call Transportation or School immediately (according to policy or procedures) .

##### **Offer Alternatives**

Suggest alternative transportation options or offer assistance. Do not leave student without a plan.

#### ENSURING SAFETY

---

##### **Secure Bus Doors**

Ensure bus doors are securely closed to prevent unauthorized entry.

##### **Contact Authorities**

Notify law enforcement, school administration or dispatch for assistance if the situation escalates.

##### **Ensure Passenger Comfort**

Reassure passengers of their safety and address any concerns.

Notes: \_\_\_\_\_

---

---

# COMPETENCY 2

# Passenger Management

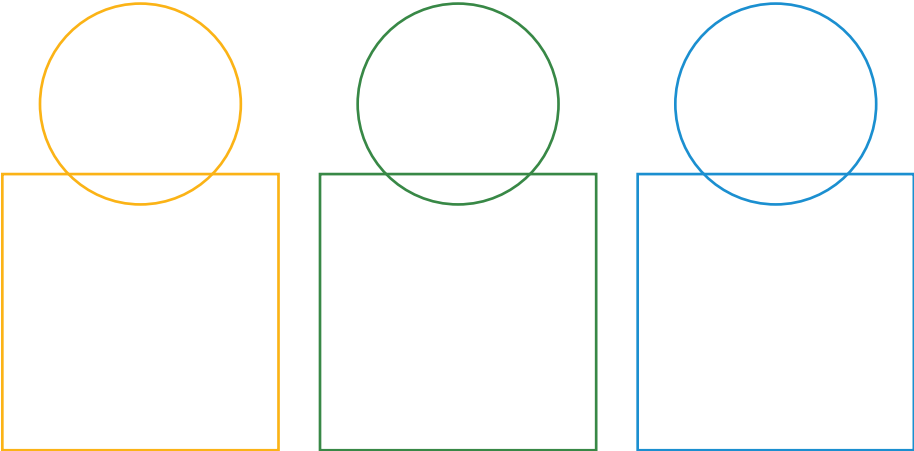



# Behaviour Management

Setting guidelines and limits on passenger behaviour can help create an understanding that passengers are equally responsible for a safe and enjoyable trip. Passenger responsibilities and consequences should be posted in the bus and reviewed at the start of the school year, after every major holiday or whenever the need arises.

**When establishing passenger responsibilities, ensure they are:**

- Concise and easy to understand for all ages
- Very specific
- Limited in number
- Within the school division or company policies

*Mentor, share the school division/bus contractor approved responsibilities document with trainee.*

## Passenger Responsibilities

Below is a sample of passenger responsibilities—modify or use this as-is. Before sharing responsibilities with passengers, ensure they are approved by the person responsible for passenger management in the school division/bus contractor.

1. Always obey the directions of the bus driver.
2. Remain seated while the bus is in motion. The bus driver will let you know when you can get up and exit the bus.
3. Ensure that nothing is extended or tossed outside of the bus through open windows.
4. No fighting, teasing, or bullying.
5. No loud or distracting noises.
6. Wear appropriate attire for the weather.

Notes: \_\_\_\_\_

\_\_\_\_\_

\_\_\_\_\_

\_\_\_\_\_

# Acceptable Consequences

Consequences are a result of an action. Whenever there are responsibilities, there are consequences. A passenger's choices have consequences. When addressing a passenger regarding a poor choice, always remind them it was their decision to do what they did, and the consequence is a direct result. Consequences must be applied consistently and equally to every passenger.

## Acceptable consequences are:

- A warning.
- Change of assigned seat by bus driver.
- Private conference with the bus driver.
- Communication of behaviour to parent/guardian and/or the principal.
- Private conference with the principal.

## ISSUING A WARNING

---

When giving a passenger a warning, use a progressively negative choice strategy. This means that they have a choice, but one is more unpleasant than the other.

An example would be **“You can remain seated for the remainder of the ride to school, or you can move up to the front seat. What is your choice?”** The passenger maintains their dignity by making a choice and they will usually choose to stay seated in their seat.

If they do not, remember it is still their choice and the consequence needs to be

implemented. When implementing the movement to the front seat, remember that the driver is not to touch a passenger except to restrain them from hurting other passengers or themselves.

Once the decision is made, a congratulatory high five is acceptable and so is genuinely stating **“good idea”** to the individual. Most actions will stop with a warning. If they do not after three warnings, the consequence would move to the next stage—the change of assigned seat.

## CHANGING OF ASSIGNED SEAT

---

The assigned seat is usually in the front passenger side of the bus. Never move a passenger to the back of the bus when applying a consequence. The severity of the consequence is in direct relationship to the severity of the action. More serious incidents, such as fighting, would necessitate going immediately to number four of the

acceptable consequences above. When at stage three, do not overdo it. We sometimes have a tendency to over-explain ourselves, and that can make communicating to the passenger more difficult. If passenger responsibilities have been reviewed, then the passenger should know why this decision has been made.



## PASSENGER-DRIVER CONFERENCE

---

Always conduct a passenger-driver conference at the school, standing outside of the bus, with another adult present (if possible). If other students are present, take the student into the school and ask for a room to talk to them in private—but do not close the door.

Note: Not all bus routes allow time for private conferences, in this instance, drivers should contact the school division/bus contractor on how best to proceed.

During the discussion, ask probing questions, such as **“What could happen to you if you are not seated, and the bus has to suddenly**

**stop or swerve to avoid something on the road?”** This reaffirms their knowledge of the responsibilities, follow up with **“Why did you choose to stand up?”**

While unlikely, there could be a good reason. If so, take this into account. If not, remind them of the poor choice they made and ask what they are going to do to correct the behaviour. If they come up with a good solution, that’s great. Research suggests that a solution coming from them has a higher chance of success. If their solution doesn’t work, then it’s time to consider further action.

## COLLABORATING WITH PARENTS AND THE PRINCIPAL

---

When handling discipline concerns regarding the school bus, drivers should work in cooperation with the school principal or their designate. The school principal is ultimately responsible for handling serious discipline issues up to and including the suspension of a passenger’s bus riding privileges. By establishing communication

and guidelines before there is a problem, solutions can typically be achieved quickly. With more serious discipline problems, a meeting between the bus driver and the school principal, the parents/guardians, and the passenger may be required. Notify your immediate supervisor that a meeting is being arranged as they may also want to attend.

### Non-Acceptable Passenger Management Tools

#### **Empty Threats**

Do NOT make empty threats. Should a threat be made to call a parent, it must be followed through with an actual call to the parent.

#### **Brake Checks**

Do NOT brake check to teach students that it is dangerous to stand up when the bus is moving. This is very dangerous and will not be tolerated.

#### **Physical Touching**

NEVER touch a student, unless it is to intervene in a physical altercation where their safety is in jeopardy.

# Seating Plans

It is extremely important that all passengers have assigned seats. In some school divisions in Alberta assigned seats are mandated by contract. While most passengers will remain seated, other passengers may need to be reminded often within a short period of time. They may forget, and when reminded, may choose to ignore the request. Monitor their attention timespan, if they are only able to stay focused for three minutes, then at two minutes and 30 seconds say, “**Thank you for remaining seated**”. It reinforces, in a positive way, what is required and both passenger and driver feel better.

## Reasons for assigned seats include:

- In the event of vandalism, identifying the individual responsible becomes straightforward.
- Aid in discipline concerns enabling the rearrangement of passengers who appear to be in conflict or who exacerbate each other’s disruptive behaviour.
- In the event of an emergency, it becomes easier to account for all passengers.

*Mentor and trainee, discuss the benefits of a seating plan and how to implement a plan successfully.*

## Why do we need assigned seats?

Scan the QR code with your mobile device or click to on the text to access the video.

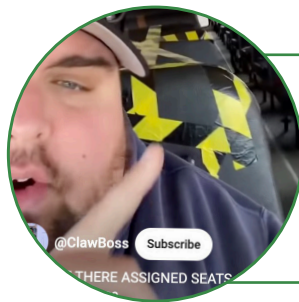

[Why Are There Assigned Seats on School Buses?](#)



---

## Seating Young Passengers

When allocating seats, it’s important to acknowledge the natural hierarchy among passengers and, typically, allowing them to choose their preferred seats is best. However, an exception applies to Kindergarten and Grade 1 passengers, who are generally placed at the front of the bus for safety reasons. Should a request arise for a Kindergarten or Grade 1 passenger to sit at the back with an older sibling, it’s crucial to communicate the potential exposure to inappropriate language and behaviour from older passengers.

In cases where siblings need to sit together, the older sibling should move to the front alongside the younger one. After passengers select their seats, they should be informed that any issues with discipline will prompt adjustments to the seating arrangement. Seating for Kindergarten and Grade 1 passengers should be assigned immediately, while seats for other passengers can be determined after three to four days on the route, allowing time to observe the bus dynamics. It’s essential to keep the seating plan up to date and integrate it with the routing information.

# Pre-Trip and Post-Trip Inspections

Conducting daily inspections ensures that the bus is mechanically safe to provide transportation to passengers. Promptly identifying and reporting defects to the division's mechanic or contractor is vital to allow appropriate time for repairs before the next run. It is also important to ensure that school divisions and contractors remain National Safety Code compliant in the recording of defects.



- Trainee, scan the QR code with your mobile device or click on the text to access the videos and resources to learn proper pre-trip and post-trip inspection techniques.*





**Introduction to Pre-Trips and Post-Trips**



**Exterior Inspection**



**Interior Inspection**





**Post-Trip Inspection**

---

## Child CheckMate System

The Child CheckMate system helps ensure that all children have safely disembarked the vehicle upon completion of each run.

- Trainee, scan the QR code with your mobile device or click on the text to learn more about the Child CheckMate System.*



**Child CheckMate Process**

# Loading and Unloading

Although school bus travel is the safest means of student transportation, the greatest danger for students occurs during the loading and unloading process. The following videos demonstrates how to properly secure, load, and unload passengers. Passengers with special needs may require additional supports. (see pg. 26, "Loading and Unloading Using a Lift").



*Trainee, scan the QR code with your mobile device or click on the text to learn the proper techniques for loading and unloading.*



[Passenger Loading and Unloading General](#)





[Rural Loading Left Hand](#)



[Loading with Turn Arouds](#)





[Rural Unloading Left Hand Side](#)





[Urban Loading and Unloading](#)





[Rural Unloading Right Hand Side](#)



[Rural Loading Student Yard](#)



[Rural Unloading with Turn Around Right Hand Side](#)



[Rural Loading and Unloading with Turn Around Left Hand Side](#)

# Safety Zones

Buses have many areas around them that are not visible to the driver, ensuring passengers that have unloaded are in the 'safety zone' is critical to safety. Unfortunately, passengers have been run over when the bus driver pulled away thinking that the passenger had gone into their home or walked out of sight, but instead the passenger had gone under the bus to pick up something. Or after getting off the bus, the passenger climbed onto a snowbank beside the bus and then slipped off the snowbank and slid under the bus just as it was pulling away. The only way the driver can ensure passengers are not under the bus is to:

- Assign a safety zone for passengers waiting for the bus.
- Assign a safety zone for passengers to go to once they have gotten off the bus.
- Count passengers inside the bus, as they exit, and once passengers are in the safety zone.

*Mentor and trainee, review and discuss the safety zone procedure.*

## SAFETY ZONE PROCEDURE

---

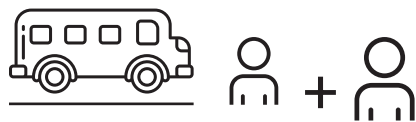

1. At each stop, count the passengers as they exit the bus.

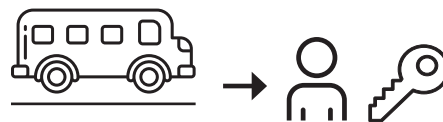

3. If a passenger is unaccounted for—secure the bus, do a total shutdown, take the key, exit the bus, and check around the bus.



2. Prior to pulling away from the bus stop, check the safety zone with a glance, counting passengers to ensure all are accounted for.



4. If the missing passenger is located, return to the bus and proceed on the route. If the missing passenger is not located, follow the school division/bus contractor policies with appropriate escalation to local police.

## Safety Zone Procedures with Alternately Flashing Lights

Unless there is a ministerial regulation or municipal bylaw that directs otherwise, the alternating amber and red flashing lights and stop arm must be used when passengers are being loaded or unloaded and never at other times. The general requirement of the TSA and Use of Highway and Rules of the Road Regulation is that these signals are always and only used when loading and unloading passengers. This helps to keep other road users alert to their importance for safety. A bus driver will need to know if there is any exception in place for all or part of their route. By-laws may exist in areas that prohibit the use of the amber and red flashing lights.

- Mentor, discuss with trainee relevant local route items to be aware of such as urban alternately flashing lights bylaws or dangers on routes.*

### WHERE ALTERNATELY FLASHING LIGHTS ARE REQUIRED

**Where alternately flashing lights are required, follow these guidelines for safe zones:**

- Passengers living on the opposite side of the road would go to a designated safety zone on that side of the road where the driver can see them.
- Passengers living on the same side of the road would go to a safety zone that is clear of the bus and where the driver can see them.

**NOTE:** The exact location and setup of a rural left-side passenger pick-up safety zone may vary based on local regulations, terrain, and road conditions. It is essential to regularly evaluate and adjust to ensure optimal safety.

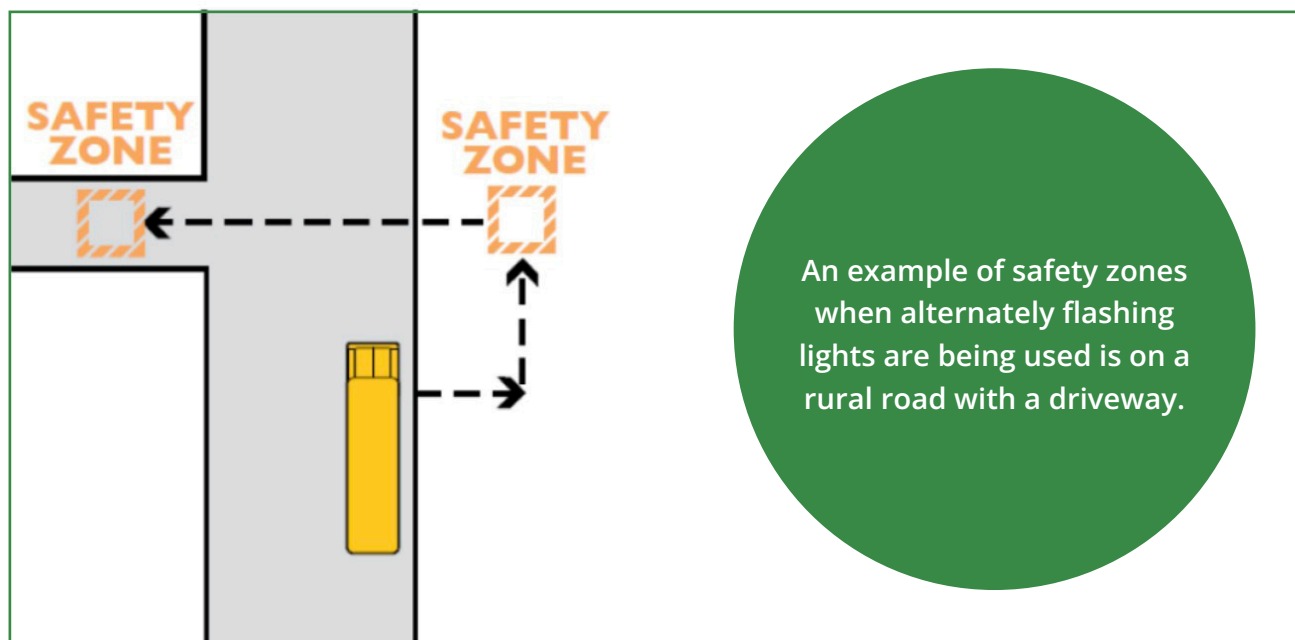

## WHERE ALTERNATELY FLASHING LIGHTS ARE PROHIBITED

Where alternately flashing lights are prohibited by local bylaws, such as in many urban areas, follow these guidelines for safety zones:

- If passengers live on both sides of the road, there are two safety zones.
- If picking up and dropping off in the same location, there is one safety zone.
- If the route is reversed on the p.m. route, there are two safety zones—one for the a.m. and one for the p.m.

**Remind passengers crossing the road without the benefit of the alternately flashing lights to:**

- Wait in the safety zone until the bus departs.
- Go to the intersection.
- Look around 360 degrees and, when safe, cross the road using the **Point, Pause, and Proceed** method. This is where the child holds their arm straight out at a right angle to their body pointing in the direction they wish to cross, while checking for traffic when in the crosswalk.

**NOTE:** The Point, Pause, and Proceed method should be reviewed at the beginning of the year, three times throughout the year, and whenever a new passenger boards the bus for the first time.

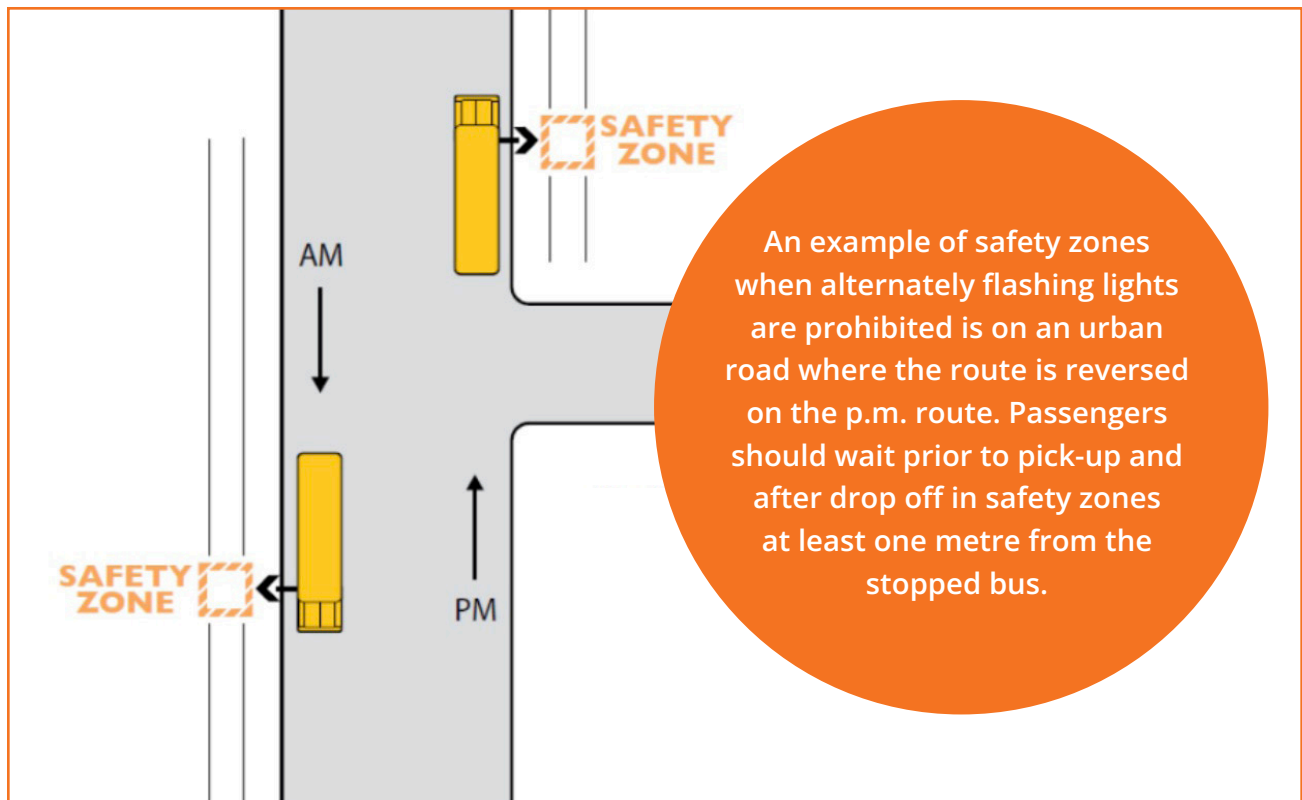





## Caregiver Compliance

At times, caregivers may walk a passenger in front or behind a bus before the bus has departed. In this instance, in a respectful manner, explain that passengers have been trained to wait in a designated safety zone. Emphasize that safety zones are important for the safety of the child. If the caregiver refuses to comply, bring it to the attention of the school administration.

- Mentor and trainee, discuss different approaches. Consider creating a script to refer to when faced with an issue with caregiver compliance.***

Notes: \_\_\_\_\_

\_\_\_\_\_

\_\_\_\_\_

\_\_\_\_\_

\_\_\_\_\_

## Reminders to Students

- Trainee, use this as a guide to remind students of bus stop safety.***

1. Arrive at the bus stop 3-5 minutes before the bus is scheduled to arrive.
2. Stand at least 1.5 metres away from the curb.
3. Stay in your designated safety zone until the bus driver signals that it is safe.
4. When the red flashing lights are used, make eye contact with the bus driver, then cross in front of the bus at least 10 paces (or 5 giant steps).
5. Check for traffic before stepping out from in front of the bus.
6. When red flashing lights are not used, wait until the bus leaves, and cross the street behind the bus at a designated crosswalk or intersection.
7. If you drop something near the bus, do not pick it up, tell the bus driver instead.
8. The bus stop is not a place to run or play.



# Passengers with Special Needs

**SUGGESTED TIME:**  **3 HRS** (of the total 9 hours for Competency 2)

Transporting passengers with special needs may require the driver to exercise a greater level of attention during the loading, transporting, and unloading processes. Safety and adherence to proper procedures are essential in ensuring the well-being of all passengers.

## **Familiarity with each passenger's abilities and needs is crucial for:**

- Adjusting driving practices appropriately.
- Determining the type of assistance required for boarding or disembarking.
- Implementing safety measures for all passengers on the route.

---

## Best Practices for Transporting Passengers with Special Needs

*Mentor and trainee, review and discuss these best practices.*

### **Road Crossing**

Passengers with disabilities should not cross roads unaccompanied. A responsible person, such as a parent, caregiver, or, in certain conditions, a mature and responsible older child, should assist according to the carrier or school policy.

### **Loading and Unloading**

Whenever practical, perform these actions door-to-door or hand-to-hand, following the specific policies for the passenger.

### **Supervision Upon Arrival**

Ensure the passenger safely enters their destination and is received by a responsible individual if needed.

### **Emergency Protocols**

If no responsible person is available to receive the passenger, and no prior arrangements have been made, return the passenger to the bus and contact a supervisor or the caregiver immediately.

### **Awareness and Sensitivity**

Understand the unique needs of passengers, which may include cognitive, developmental, sensory, or physical disabilities, and the requirement for mobility devices and supports.

### **Extra Time Requirement**

Allocate additional time for the safe securement of passengers with disabilities or mobility devices.

### **Assistance**

Directly ask passengers or their caregivers about the best ways to assist them.

### **Preferred Communication Methods**

Discover each passenger's preferred method of communication. Adjust interaction based on their comfort and needs.

### **Advance Notice**

Inform passengers, especially those with autism spectrum conditions, of any route changes due to external factors like collisions, weather, or construction, in advance.

# Guidelines for a Passenger Using a Mobility Device

## PREPARING FOR MOBILITY DEVICES

---

### Designated Stops

Choose stops that facilitate easier and faster loading and unloading, allowing sufficient space for ramps/lifts and wheelchair maneuvering.

### Visibility and Accessibility

Ensure the stop is visible to other motorists and accessible if the original stop is unavailable. Aim for drive-through routes to avoid backing up and challenging terrain.

**NOTE:** To prevent battery acid spills and potential injuries, avoid tipping power-drive wheelchairs or scooters more than a few inches unless the batteries have been removed.

### Vehicle Operation

Understand how to operate all vehicle features for loading and unloading. If there are any operational questions, contact a supervisor before use.

### Mobility Aids

Familiarize yourself with the common types of mobility aids, including standard manual wheelchairs, power-drive wheelchairs, and motorized scooters.

## PASSENGER SAFETY VESTS AND RESTRAINT SYSTEMS

---

Safety vests and restraints come in a variety of designs. They may be embedded into the bus seat or may have to be mounted around a bus seat. Passengers must be restrained with a system that includes both lap and shoulder belts anchored to the floor retractors, as wheelchair-integrated lap belts or vests may not prevent ejection in sudden movements or collisions. Following these guidelines ensures both the safety and dignity of passengers using mobility aids during transport.

### Lap Belt Attachment

- Connect the shorter lap belt end to the pin connector on the aisle-side rear retractor. Store the lap and shoulder belt assembly in its designated location to keep it clean and off the floor. Detach the belt from its storage pin and attach it to the rear retractor next to the wall.

### Securing the Passenger

- Wrap the belt around the passenger, keeping it away from their body, and secure it to the opposite rear retractor.

### Shoulder Strap

- Handle the shoulder strap carefully to respect the passenger's personal space. Clip one end to the pin connector on the lap belt, positioned low on the passenger's hip on the aisle side. Some assemblies might not require separate attachment of the shoulder belt to the lap belt.
- Adjust the shoulder strap gently to ensure a snug but comfortable fit.

*To learn more, see the video on the next page.*



*Trainee, scan the QR code with your mobile device or click on the text to learn about how to use a safety vest and seat mount restraints.*

**Safety Vest and Seat Mount**



## PASSENGER USING A WHEELCHAIR

When securing passengers who remain in their wheelchairs, use a four-point tie-down system. Always adhere to the manufacturer’s guidelines and company policies for proper passenger securing if using alternate restraint systems.

### Wheelchair Lap Belt

- Ensure passengers have their wheelchair’s lap belt securely fastened if available.

### Positioning the Wheelchair

- Place the wheelchair centrally between the four plates or tracks on the bus floor.
- Secure the front of the wheelchair first. Connect the clips to the floor plate using the front retractors, which should engage with the two outer plates or tracks. Extend the belt as needed to attach the hook.
- Attach the hook to a solid frame part of the wheelchair, aiming for a level close to the seat bottom, creating a 45-degree angle with the belts relative to the floor.

### Securing the Rear

- Follow the same steps for the rear belts, ensuring they also form a 45-degree angle to the floor. For manual wheelchairs, attach the hook to a solid frame section where the seat meets the back.
- After attaching all four retractors, test the wheelchair’s stability by gently pushing and pulling it. The wheelchair should be secure without wobbling, but avoid overtightening.

*Trainee, scan the QR code with your mobile device or click on the text to learn about wheelchair loading, unloading, and securement.*



**Loading: Step 1**



**Loading: Step 2**



**Unloading: Step 1**



**Unloading: Step 2**



## SECURING SCOOTERS

---

The safest method for traveling with a passenger who uses a scooter involves having the passenger transfer to a seat and securing them with a lap belt and shoulder strap. Some companies require this practice.

### Challenges in Securing Scooters

- Securing three- and four-wheel scooters can be challenging, especially without clips or rings on the rear framework.
- Passengers are recommended to contact the scooter manufacturer for adjustments rather than attempting modifications independently, to avoid scooter damage and ensure the safety of all passengers.

### Procedures for Securing Scooters

- Follow the same procedures as for wheelchairs, adhering to the manufacturer's guidelines and company policies. Use the four-point system on the floor, ensuring the straps are tight yet not overly so.
- Scooters should have clips, bars, or D-rings installed by the manufacturer on the rear framework for safe securing. Attaching clips around the pedestal or chair frame

poses a risk of detachment in a collision.

- The most secure method involves looping the belts through these attachments on the rear framework, setting the belts at 45-degree angles to the floor. Other methods, like attaching clips around the pedestal or chair frame, are less safe and secure.
- For the front of the scooter, secure by hooking each belt to the tiller and crossing them in front, then attaching the belts to the floor plates and adjusting as necessary.

### Addressing Passenger Reluctance

- If a passenger is reluctant to leave their scooter, discuss the importance of safety for themselves and others on the bus, highlighting the risk of remaining on the scooter, especially its potential to tip over during sharp turns due to its high centre of gravity.

## LOADING AND UNLOADING USING A LIFT

---

Assisting passengers on and off a vehicle with a lift involves understanding the vehicle's entry system. The safest method of using a lift depends on the type of equipment and the size of the mobility aid, among other factors.



**For side-loading lifts, passengers should face away from the vehicle.**

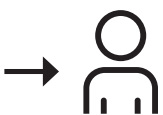

**For rear-loading lifts, passengers should face towards the vehicle.**

Adhere to the following procedures for all mobility aids, ensuring the safety plate is raised before operating the lift if it does not raise automatically. Establish a routine to follow, and if interrupted, revert to this routine to ensure no steps are missed or incomplete. It is crucial to maintain constant contact with the mobility aid.

**The following procedure is recommended for both types of lifts:**

**Loading:**

- Ensure the passenger in the chair has secured their lap belt.
- Verify that the doors are locked open and cannot swing closed.
- Carefully lower the lift to ground level, avoiding impact with the ground or resting it on uneven surfaces.
- Position the mobility aid on the lift, ensuring the passenger faces away from the vehicle and that the passenger's feet, legs, or parts of the mobility aid will not be caught between the vehicle and the lift.
- Engage the parking brake on manual wheelchairs. For powered wheelchairs, turn the power off.
- Raise the safety plate on the lift (automatically done on some vehicles).
- Drivers may accompany the passenger on the lift when possible, but should consult the manufacturer's specifications as some lifts may not support additional weight. Be aware that some scooters and electric chairs are too large for drivers to accompany on the lift, and newer buses may prohibit the additional weight of a driver on the lift.

- Maintain one hand on the mobility aid to monitor any movement.
- Release the brakes of the mobility aid.
- Move the mobility aid into the vehicle and engage its brakes.
- Inside the vehicle, position the mobility aid at the desired location, ensuring the passenger's feet are clear.
- Secure using tie-downs, seatbelts, shoulder straps, and engage the mobility aid brakes.
- Return the lift to its upright position and close the doors before re-entering the vehicle.

**Unloading**

- To unload, reverse the procedures above.

**Lift Failure**

Should a power or equipment failure occur while passengers are on the bus, manual operation of the lift becomes necessary. Follow instructions provided by the manufacturer for manual operation of the wheelchair lift.

*Trainee, scan the QR code with your mobile device or click on the text to learn how to load and unload a passenger using different types of lifts.*



Using a Powered Wheelchair Lift



Using a Non-Powered Wheelchair Lift (Manual)

## BUS EVACUATION WITH PASSENGERS WITH SPECIAL NEEDS

---

It is important to remember that no two emergencies are the same and school buses may transport passengers of various different abilities and needs. This video provides an idea of what an evacuation could entail with passengers with special needs.

- Trainee, scan the QR code with your mobile device or click on the text to learn how to use a safety vest and seat mount restraints.*



[Special Needs Bus Evacuation](#)



---

## Cargo Securement

Drivers must secure snow brushes, sand jugs etc. securely in their bus so they cannot move and become a projectile endangering the students or the driver.

- Mentor and trainee, review and discuss the securement act and ways to secure various items such as garbage can, sand shaker, etc.*

---

### CARGO SECUREMENT: ALBERTA REGULATION 1/2005 TRAFFIC SAFETY ACT

#### Safety Responsibility

- (1) A carrier shall not permit a driver to operate a commercial vehicle where the cargo transported in or on the vehicle is not contained, immobilized or secured in accordance with the Standard as it relates to the particular type of commercial vehicle.
- (2) A driver shall not operate a commercial vehicle where the cargo transported in or on the vehicle is not contained, immobilized or secured in accordance with the Standard as it relates to the particular type of commercial vehicle.

#### Cargo Securement

- 4 A driver or carrier must ensure that cargo transported by a commercial vehicle is contained, immobilized or secured so that it cannot
  - (a) leak, spill, blow off, fall from, fall through or otherwise be dislodged from the vehicle, or
  - (b) shift upon or within the vehicle to such an extent that the vehicle's stability or manoeuvrability is adversely affected.



# Onboard Observation and Shadowing

Practical or real-life training for bus drivers regarding passenger management can significantly enhance their skills. Through on-bus training, mentors can demonstrate proper techniques in action.

## MENTOR DEMONSTRATION

---

- Mentors, while on the bus, demonstrate the following to trainee:*
  - General procedures of how to load and unload passengers on the road.*
  - How to load and secure mobility devices ( if applicable)*
  - How to use various harnesses ( if applicable)*
  - How to manually use a lift if there is power failure*
  - How to use various safety vests (if applicable)*

## TRAINEE PRACTICE

---

- Trainee, while on the bus, practice the following:*
  - Loading and unloading passengers on the road*
  - Loading and securing mobility devices ( if applicable)*
  - Using various harnesses ( if applicable)*
  - Finding safe and appropriate loading and unloading areas for a mobility device— with adequate space and sightlines, and free of sowbanks, puddles, and potholes.*
  - Communicating with passengers with special needs. While role playing with the mentor, practice greeting and informing passengers of changes to the route— proactively communicating on actions with mobility devices.*
  - Using the lift manually if there is power failure*
  - Installing various safety vests and how to properly use them (if applicable)*

## RIDE-ALONG TRAINING

---

- Mentor, arrange for trainee to shadow experienced drivers allowing them to observe real interactions with passengers and replicate common passenger-related scenarios such as:*
  - A passenger has a problem with their bus pass.*
  - Assisting a passenger with disabilities or special needs and/or a passenger where English is not their first language.*
  - A conflict occurs between passengers and where a driver must use de-escalation techniques.*
  - A passenger complains about various issues, requiring drivers to practice empathy and conflict resolution.*
  - An emergency procedure requiring evacuation or handling medical incidents on board.*
  - A driver must practice active listening, empathy, clear communication, and professional demeanor.*
  
- Mentor, after each ride-along, conduct a debriefing session. Offer constructive feedback on trainee's performance, highlight successful strategies used during the ride, and encourage trainee to share their experiences and insights.*

Notes: \_\_\_\_\_

\_\_\_\_\_

\_\_\_\_\_

\_\_\_\_\_

\_\_\_\_\_

\_\_\_\_\_

\_\_\_\_\_

\_\_\_\_\_

\_\_\_\_\_

\_\_\_\_\_

\_\_\_\_\_

\_\_\_\_\_



## COMPETENCY 3

# Effective Communication

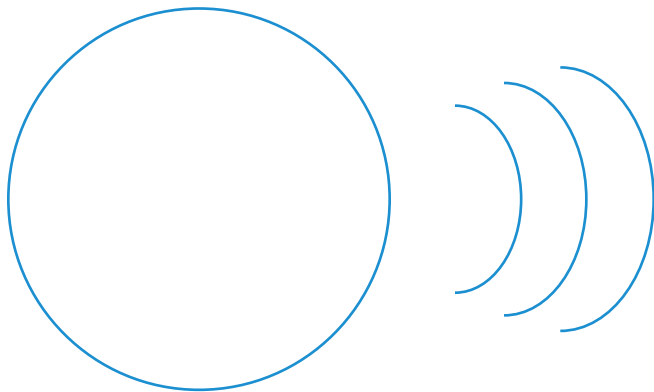

# Effective Communication

SUGGESTED TIME:  HRS

Effective communication is essential for bus drivers for a variety of reasons. This section aims to equip drivers with the necessary skills to effectively communicate with students, parents, school administrators, dispatch personnel, and other motorists. In addition to educational materials, role-playing exercises and practical experience during ride-alongs will help to enhance a driver’s ability to convey information clearly and respond appropriately in diverse interactions.

---

## In This Section

Guidelines for Effective Communication .....	33
Verbal and Non-verbal Communication Skills.....	34
Creating a Positive Environment .....	36
Communication with Parents .....	37
Communication with School Staff.....	38
Communication with the Motoring Public.....	40
Communication During an Emergency .....	41
Effective Communication Role-Playing.....	42

*Add important notes here for quick reference.*

---

---

---

---

---

---

# Guidelines for Effective Communication

Effective communication is crucial for bus drivers, who engage with a variety of people every day. It's important to note that successful communication extends beyond words; non-verbal cues like body language and facial expressions play a significant role. By maintaining an open and welcoming demeanor, bus drivers can greatly improve the overall passenger experience.

*Mentor and trainee, review and discuss the following guidelines for effective communication.*

## **Clarity and Conciseness**

Speak in a clear, jargon-free manner. Keep all announcements and instructions brief and straightforward to ensure they are understandable to everyone.

## **Active Listening**

Pay careful attention to passengers' questions or issues. Show that you have heard them by acknowledging their concerns and responding appropriately.

## **Calmness and Patience**

Stay calm, especially in difficult situations or when dealing with challenging passengers. Exhibiting patience can help to ease tensions.

## **Courtesy and Politeness**

Always use polite language and maintain a friendly attitude. A simple smile or greeting can foster a welcoming environment.

## **Clear Announcements**

Articulate announcements distinctly and ensure they are loud enough for all passengers to hear and comprehend.

## **Conflict Resolution**

Approach conflicts with calmness and professionalism. Aim to de-escalate tensions and find amicable solutions.

## **Swearing and Inappropriate Language**

Do not swear or use inappropriate language. What is acceptable to a driver might not be acceptable for use with passengers. For example, use "be quiet" instead of "shut up".

## **Empathy**

Recognize that passengers may have different needs or be experiencing various emotions. Demonstrate understanding and compassion for their situations.

## **Safety Instructions**

Communicate safety guidelines clearly. If necessary, repeat the instructions to guarantee everyone's understanding of the safety measures.

## **Cultural Sensitivity**

Show respect for the cultural diversity of your passengers. Be aware of and sensitive to cultural differences in your communications.

## **Team Communication**

Ensure clear and effective coordination with fellow drivers and staff. Good communication within the team is essential for efficient operations.

# Verbal and Non-verbal Communication Skills

Effective communication with students, parents, and school staff regarding student behaviour requires clarity, empathy, and professionalism, along with a mix of both verbal and non-verbal cues. Awareness of how your body language and other silent signals come across, both effective and ineffective, is crucial. It can significantly impact how messages are perceived and understood in various interactions, helping make things clearer and smoother for everyone.

---

## Effective Verbal Communication

- Mentor and trainee, review these ideas for how to communicate positively and brainstorm some ideas of your own.*



### POSITIVE REINFORCEMENT

**“I appreciate your cooperation.”**  
**“Thank you for following the rules.”**  
**“Great job on showing respect to others.”**



### ADDRESSING BEHAVIOUR

**“Let’s work together to maintain a safe environment.”**  
**“It’s important to listen to instructions for everyone’s safety.”**  
**“I need your help in keeping the bus peaceful for everyone.”**

---

## Effective Non-Verbal Communication

- Trainee, consider ways to demonstrate these non-verbal communication cues.*

### Open Posture

Adopt an open stance, with arms relaxed and not crossed, to signal approachability and openness.

### Eye Contact

Making suitable eye contact demonstrates focus and interest, ensuring it feels engaging rather than overwhelming.

### Facial Expressions

Expressiveness: Align facial expressions with your emotions to accurately communicate feelings and intentions.

### Smiling

A sincere smile can communicate warmth, friendliness, and make you more approachable.

### **Natural Movements**

Employ natural, intentional gestures that support your verbal messages, aiding in clearer communication.

### **Gestures**

Apply gestures sparingly to underscore points without becoming distracting or excessive.

### **Appropriate Distance**

Keep a respectful distance during conversations, considering personal space and comfort.

### **Cultural Sensitivity in Proximity**

Be mindful and adaptable to different cultural expectations concerning personal space.

### **Varied Tone**

Use tone variations to express emotions and place emphasis, enriching your verbal communication.

### **Controlled Volume**

Ensure your speaking volume is clear and audible, yet not overly loud or too quiet.

---

## **Ineffective Non-Verbal Communication**

*Trainee, consider ways to avoid doing these non-verbal communication cues.*

### **Crossed Arms/Legs**

Indicates defensiveness or unwillingness to open up.

### **Avoiding Eye Contact**

Suggests lack of interest, dishonesty, or unease.

### **Blank Look**

May appear disengaged or indifferent.

### **Mismatched Expressions**

Can cause confusion if they don't align with the spoken message.

### **Excessive Movements**

Too much gesturing can distract from the main message.

### **Offensive Gestures**

Gestures that are culturally insensitive or not fitting the context.

### **Too Close**

Encroaching on someone's space can make them feel uncomfortable or threatened.

### **Ignoring Boundaries**

Not respecting personal space can lead to awkwardness.

### **Monotone Speaking**

Lacking tone variation can make the conversation uninteresting.

### **Wrong Volume**

Speaking too loudly or quietly can misrepresent your feelings, like aggression or lack of confidence.

# Creating a Positive Environment

Building a positive and inclusive atmosphere on the bus means promoting a sense of belonging and mutual respect among all riders. By consistently applying the steps below, bus drivers can cultivate an environment that makes every passenger feel appreciated, respected, and part of a welcoming community, ensuring a pleasant and enjoyable journey for all.

*Mentor and trainee, review and discuss ways to implement these steps on the bus.*

## 1. Setting the Tone

- Begin the school year or greet new passengers with a friendly introduction.
- Provide an inclusive greeting like, “**Good morning, everyone! I’m [Name], your bus driver. Welcome aboard Bus 101!**”

## 2. Establishing Expectations

- Clearly outline key rules focusing on safety, respect, and inclusivity.
- Emphasize the importance of respect—discussing why it’s important for everyone to feel safe and respected on the bus.

## 3. Encouraging Positive Behaviour

- Provide positive feedback, regularly recognizing and praising good behaviour.
- Introduce a reward system for standout behaviour, such as a “**Bus Star of the Week**”.

## 4. Addressing Diversity and Inclusivity

- Celebrate diversity by fostering discussions about different cultures and interests.
- Encourage respectful and inclusive language and discourage discrimination.

## 5. Creating a Supportive Atmosphere

- Let passengers know they can come to you with concerns.
- Handle disagreements quickly and fairly, promoting harmony.

## 6. Engaging Passengers

- Incorporate fun activities like trivia or riddles during the ride.
- Organize inclusive games that allow everyone to participate.

## 7. Building Relationships

- Greet passengers by name and have friendly chats when possible.
- Express genuine interest in passengers’ lives outside of school by inquiring about hobbies and extracurricular activities, for example “**How did your volleyball game go?**”

## 8. Consistency and Adaptability

- Apply rules fairly and consistently, adapting to individual needs as necessary.
- Be flexible and ready to adjust approaches to meet evolving needs and situations.

## 9. Collaboration with School and Parents

- Work with school staff to coordinate behaviour management.
- Keep in touch with parents about bus dynamics and seek their support.

# Communication with Parents

Parents and guardians play a crucial role in the effective behavioural management of passengers on the bus. The use of specific words and phrases can lead to constructive conversations, build positive relationships, and promote teamwork in creating a safe and respectful environment on the school bus. Customizing communication to suit the unique needs and concerns of each audience is key to successfully managing behaviour issues and recognizing good behaviour.



## INFORMING ABOUT POSITIVE BEHAVIOUR

**“I wanted to let you know that your child has been a positive influence on the bus.”**

**“I appreciate your child’s respectful behaviour towards others.”**

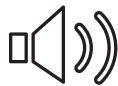

## ADDRESSING CONCERNS

**“I noticed some challenges on the bus, and I wanted to discuss ways we can work together to address them.”**

**“Your child’s safety is important to me, and I wanted to share some incidents we’ve observed to ensure their well-being.”**



## SEEKING SUPPORT

**“I believe together we can find solutions to ensure a safe and pleasant bus experience for your child.”**

**“Could we schedule a meeting to discuss some concerns and work on a plan to support your child on the bus?”**

---

# Communication with School Staff



## REPORTING POSITIVE BEHAVIOUR

**“I wanted to highlight a student’s exemplary behaviour on the bus today.”**

**“I appreciate the support and cooperation from the school in reinforcing bus safety rules.”**



## ADDRESSING ISSUES

**“I’d like to discuss a situation on the bus that may require some collaboration to address.”**

**“Could we explore strategies together to ensure consistent enforcement of bus rules?”**



## COLLABORATING FOR SOLUTIONS

**“I value our partnership in maintaining a safe environment for students during their commute.”**

**“Let’s brainstorm ideas on how we can collectively address specific behavioural challenges.”**

# Communication with Dispatch

Maintaining clear and effective communication between school bus drivers and dispatch teams is key to keeping passengers safe and ensuring everything runs smoothly. Following the radio etiquette tips below will help make sure information is shared quickly and accurately.

- Keep messages clear and conciseness to ensure effective communication.
- Use **“Over”** or **“Copy that”** to signify the end of a transmission and **“Out”** or **“10-4”** when ending communication.
- Wait for a pause before transmitting to avoid interrupting ongoing communications.

---

## School Bus Driver Etiquette



### INITIATING CONTACT

**“Dispatch, this is Bus 101.”**  
**“Good morning/afternoon, Dispatch.”**



### REPORTING STATUS OR REQUESTING ASSISTANCE

**“Bus 101 departing from [location].”**  
**“Dispatch, I need assistance at [specific location] due to traffic congestion.”**



### SHARING IMPORTANT INFORMATION

**“Dispatch, there’s a road closure on [street name], diverting to alternate route.”**  
**“Dispatch, roads are icy, exercising caution.”**

---

## Dispatch Personnel Etiquette



### ACKNOWLEDGING CONTACT

**“Bus 101, this is Dispatch, go ahead.”**  
**“Good morning/afternoon, Bus 101, go ahead.”**



### RESPONDING TO STATUS UPDATES OR REQUESTS

**“Copy that, Bus 101, noted your departure.”**  
**“Assistance is en route to your location, Bus 101.”**



### PROVIDING INSTRUCTIONS OR INFORMATION

**“Bus 101, take the next left turn for your alternate route.”**  
**“All buses, be advised of heavy traffic on [road name], consider alternative routes.”**



# Driver-Dispatch Communication During an Emergency

During an emergency situation, drivers should use clear and concise language to declare an emergency, such as “Mayday” or “Emergency, Bus 101, please call my cell”. Never announce the details of the emergency over the radio where thousands of students could be listening. Dispatch should immediately respond and provide necessary support or emergency services as required.

## IMPORTANT INFORMATION TO COMMUNICATE INCLUDES:

---

### **Specific Details**

Clearly state the nature of the emergency, whether it's an accident, mechanical failure, fire, medical issue, or any other crisis.

### **Severity**

Communicate the severity of the situation as accurately as possible to indicate the level of urgency.

### **Exact Location**

Provide the exact location of the bus, including street names, landmarks, or any other identifiable information.

### **Bus Identification**

Clearly state the bus number or any distinguishing features to aid responders in locating the bus.

### **Passenger Count**

Communicate the number of passengers on board, including students, staff, or any other individuals.

### **Injury Assessment**

Report the number and severity of injuries, if any, to ensure appropriate medical assistance.

### **Hazard Assessment**

Hazards Present: Identify any hazards, such as fire, smoke, leaking fluids, or potential dangers, to help responders assess the situation.

### **Road Conditions**

Report road conditions or any impediments that might hinder emergency services' access to the location. Learn how to use 511 Alberta to look at road conditions, view where the graders have been, as well as construction areas to avoid.

Notes: \_\_\_\_\_

\_\_\_\_\_

\_\_\_\_\_

\_\_\_\_\_

\_\_\_\_\_

\_\_\_\_\_

---

# Communication with the Motoring Public

School bus drivers use specific lights and signals to effectively communicate their intentions with other motorists, ensuring the safety of passengers and other road users during their commute. Below are common communication techniques.

- Mentor and trainee, review and discuss these common techniques used by bus drivers to communicate effectively with other motorists.*

## Stop Arm and Flashing Lights

- When picking up or dropping off passengers, the school bus extends its stop arm, signaling other drivers to stop and not pass the bus.
- Alongside the stop arm, flashing red lights indicate that passengers are entering or exiting the bus. This signals all vehicles to stop until the lights are turned off, ensuring passenger safety.

## Turn Indicators

- Using turn signals when changing lanes or making turns informs other drivers of the bus's intended direction, allowing for safer maneuvering.
- Drivers use turn signals well in advance to indicate their intention to change lanes, providing ample time for surrounding vehicles to adjust.

## Headlights and High Beams

- Bus drivers use headlights during dawn, dusk, or low-light conditions to enhance visibility for themselves and other drivers.
- When approaching other vehicles, bus drivers should dim their high beams to avoid blinding oncoming drivers.

## Use of Horn

- In emergency situations or to alert other drivers of imminent danger, drivers may use the horn to signal and grab attention.

## Hazard Lights or Flashers

- Use hazard lights when making temporary stops, such as for a breakdown or for picking up or dropping off passengers where there is no designated stop.
- Hazard lights signal caution to other drivers, indicating that the bus might be moving at a slower pace or facing an obstacle.
- When involved in a collision or other emergency situations, drivers must use the hazard warning lights on the bus.

## Advanced Warning Triangles

- In the case of a collision or breakdown, use the provided warning triangles on the bus to mark and protect the scene, alerting other drivers of the hazard.
- Triangles should be placed strategically to warn oncoming traffic from both directions, allowing drivers sufficient time to slow down and avoid the incident.

## Safe Maneuvering

- Following traffic rules and adhering to safe driving practices communicates the bus driver's intent to other drivers, promoting safe interactions on the road.
- Defensive driving techniques employed by bus drivers signal their focus on safety and anticipation of potential hazards.

# Communication During an Emergency

Clear and accurate communication of this information during a school bus emergency or evacuation helps responders assess the situation promptly, coordinate resources effectively, and take necessary actions to ensure the safety and well-being of all individuals involved.

## During an emergency remember to:

- Communicate if an evacuation is necessary and any assistance required for safe evacuation of passengers.
- Relay any safety measures initiated, such as using fire extinguishers, activating emergency exits, or administering first aid.
- Set out advanced warning triangles to communicate to other motorists.
- Maintain calm and composed while providing reassurance to passengers.
- Request cooperation and compliance from passengers to ensure their safety.
- Provide regular updates to emergency services and authorities as the situation evolves.
- Share any pertinent information that might aid in managing the emergency effectively.

---

## Communication with Authorities

Provide contact details for emergency services, school authorities, and dispatch for continuous communication and coordination and promptly follow any instructions given by emergency dispatchers or responders.

---

## Bus Evacuation Techniques

- Trainee, scan the QR code with your mobile device or click on the text to learn different evacuation techniques.*



**Front Door Evacuation**



**Rear Door Evacuation**



**Split Door Evacuation**

# Effective Communication Role-Playing

Role-playing scenarios is a great way for a trainee to practice and refine their communication skills in a safe and controlled environment. By engaging in these role-playing scenarios, bus drivers can enhance their communication skills and be better equipped to handle various situations they might encounter while on duty.

- Mentor, create a few school bus scenarios and role-play with trainee to help them practice effective communication techniques in common situations.*

---

## Step-by-Step guide to Create and Execute Scenarios

### STEP 1: IDENTIFY COMMUNICATION GOALS

---

**Define the key communication skills and scenarios relevant to bus drivers, such as:**

- Clear instructions to passengers.
- Dealing with difficult passengers.
- Communicating emergencies or delays.
- Handling inquiries and complaints.
- Communicating with parents/guardians regarding schedules and student behaviour.

### STEP 2: SCENARIO CREATION

---

Create realistic scenarios based on the identified communication goals. Ensure they're relevant to the drivers' everyday experiences.

**For instance:**

- Passenger asks if they could get dropped off at a friends house.
- Passenger will not sit down and keeps bothering other passengers.
- Passenger reports to driver that another passenger has stolen their backpack and eaten their lunch.

### STEP 3: TIPS FOR ROLE-PLAYING

---

When approaching role-playing, encourage participants to adopt realistic behaviour, mirroring real-life situations as closely as possible. If mentoring multiple trainees, rotate roles to ensure everyone gets an opportunity to practice different scenarios. Debrief after each role-play session. Providing constructive feedback—highlight successful communication strategies, address areas for improvement, and encourage trainees to share their insights.

## Organize the training session with a clear structure:

### Introduction

Explain the importance of effective communication and its impact.

### Instruction

Offer guidelines and tips on effective communication.

### Role-Playing

If mentoring multiple trainees, divide them into pairs or groups to act out the scenarios.

### Debriefing

After each role-play, discuss what worked well and what could be improved.

---

## STEP 4: ONGOING TRAINING AND SUPPORT

Continuously reinforce these skills through regular training sessions, workshops, and support materials. Consider integrating these scenarios into refresher courses.

### Tips for effective training:

#### Realism

Ensure scenarios mimic real-life situations as closely as possible.

#### Variety

Include a range of scenarios to cover different communication challenges.

#### Positive Reinforcement

Acknowledge and praise effective communication.

#### Encourage Creativity

Allow drivers to approach scenarios in their unique way.

---

## Scenario Ideas

### Ideas for role-playing scenarios include:

- A scenario where the driver communicates a behaviour issue of a student to parents.
- A scenario where the driver communicates a behaviour issue of students to the principal while in a meeting with the parents.
- A scenario where the driver communicates with dispatch over the radio.

---

## EXAMPLE SCENARIO: DEALING WITH AN ANGRY PASSENGER

### Role-play

One person acts as an angry passenger upset about a missed stop, while the other plays the driver.

### Goals

Practice remaining calm, active listening, and offering solutions.

### Feedback

Discuss how the driver managed the situation, including tone, empathy, and problem-solving.

# Review and Certification of Conflict Resolution, Passenger Management, and Effective Communication

For certification in Behaviour Management drivers can take the Drivafy Behavioural Management Course Modules 1 and 2.

The drivers who complete the course receive a certificate to verify proof of participation and time spent learning these skills.

There is a cost to the course.

**To learn more scan the QR code or click on the text to visit the Drivafy website.**



**Drivafy**

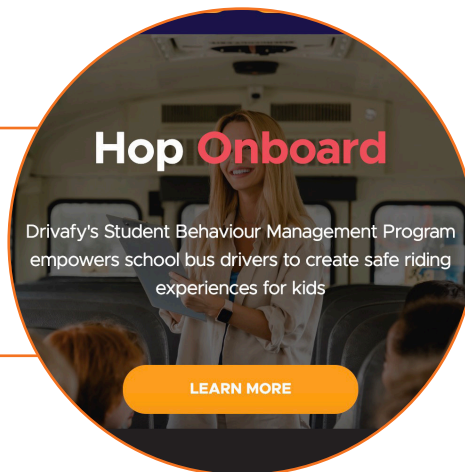

## COMPETENCY 4

# Journey Management



COMPETENCY 4

# Journey Management

SUGGESTED TIME:  HRS

Journey management is crucial for school bus drivers to ensure the safety and well-being of students. In this section, drivers will explore how by systematically planning and monitoring each journey, potential risks can be identified and addressed, contributing to a safer and more efficient transportation system.

---

## In This Section

Key Components of Journey Management..... 47

*Add important notes here for quick reference.*

---

---

---

---

---

---

---

---

---

---

---

---

---

---

---



# Key Components of Journey Management

Journey management for a school bus driver refers to the systematic planning, coordination, and monitoring of the entire transportation route or journey to ensure the safety and efficiency of the trip. This process involves assessing and mitigating potential risks, adhering to safety protocols, and managing various factors that may impact the journey. Below are the key components of journey management for a school bus driver.

- Mentor and trainee, review and discuss these components of journey management.*



## OPERATOR HANDBOOK

---

- Drivers should familiarize themselves with their school division/bus contractor handbook, ensuring a firm understanding of all guidelines, policies, and procedures.
- Questions should be directed to your supervisor for clarification.



## ANNUAL DRIVER ORIENTATION MEETINGS

---

- Driver meetings and professional development (PD) days help ensure a successful school year. Attending is vital to understanding bus driver expectations, learning new techniques, and being informed on up-to-date information.



## ROUTE PLANNING

---

- Carefully plan the school bus route, taking into consideration factors such as traffic conditions, road safety, and the location of bus stops.
- Identify alternative routes in case of road closures, construction, or other unexpected events.
- Refer to 511 Alberta as a tool to identify road issues (see pg. 51, “Checking the Weather”)
- Follow the school division/bus contractor procedure for route changes including:
  - adjusting times, and notifying parents;
  - completing route change form (if applicable);
  - notifying planner/router of any issues; and
  - contacting parents for any medical issues of new students.



## TIMING AND SCHEDULING

---

- Establish a realistic schedule for pick-up and drop-off times, considering factors like school start and end times, traffic patterns, and the number of students at each stop.
- Allow sufficient time for students to board and disembark safely.
- Be on time. Discuss the consequences of not being on-time.
- Do not provide courtesy stops as it:
  - sets unrealistic expectations for families;
  - creates liability, the bus driver will be at fault as the stop was not approved; and
  - it causes student safety issues, if a student goes missing it's unclear if they missed their stop or did not get on.



## FIELD TRIPS

---

- Drivers should be aware of their school division/bus contractor policy regarding weather and trip cancellations.
- Plan the route. Use **511 Alberta** to identify road construction, closures, and conditions (see pg. 51, "Checking the Weather" for QR code).
- Schedule times for pick up, drop off, bathroom breaks, and fueling.
- Have a list of passengers and do a check to ensure all passengers are accounted for or make sure the class/team supervisor is doing so.



## WEATHER CONDITIONS

---

- Monitor weather forecasts and adjust plans accordingly. Consider how adverse weather conditions may impact the journey, and be prepared for changes in road conditions.



## COMMUNICATION

---

- Maintain effective communication with transportation coordinators, school officials, and parents.
- Notify relevant parties of any changes to the schedule, delays, or other important information.



## DRIVER REST AND WELL-BEING

---

- Consider driver fatigue and well-being by ensuring that drivers have adequate rest periods between shifts.
- Encourage healthy habits and stress management for drivers to promote alertness during their journeys



## AVOIDING COMPLACENCY

---

- Complacency can be dangerous—switch things up. Make a point of counting at stop signs to ensure a complete stop. During an accident investigation not knowing (if you stopped at a stop sign or picked up a student) is not an acceptable response.
- Make note everyday of something different on your bus route (i.e. someone cut their grass, a new sign, snow was removed, a tree was trimmed, etc.).
- Memorize the seating plan and practice looking in the rear view mirror to quickly identify missing passengers.



## PRE-TRIP INSPECTIONS

---

- Conduct pre-trip inspections to ensure that the school bus is in proper working condition.
- Address any mechanical issues promptly, and document inspections as required.
- Conduct a Driver Mental Wellness check noting:
  - Am I rested?
  - Am I feeling well and able to safely operate my bus?
  - Have I left my personal issues at home?
  - Will my mood influence my attitude towards my passengers.



## EMERGENCY PREPAREDNESS

---

- Develop and communicate emergency procedures to the school bus driver.
- Ensure that the driver is familiar with emergency exits, first aid kits, and procedures for handling various emergency scenarios.



## STUDENT BEHAVIOUR MANAGEMENT

---

- Establish and enforce rules for passenger behaviour on the bus.
- Train drivers in effective communication and management techniques to address behavioural issues while maintaining a safe environment.



## ROUTE MONITORING

---

- Utilize GPS tracking or other monitoring systems to track the school bus' location in real-time.
- Monitor the journey to identify and respond to any deviations from the planned route or unexpected delays.



## CONTINUOUS TRAINING

---

- Provide ongoing training for school bus drivers to enhance their skills and keep them informed about changes in policies, regulations, and safety procedures.



## DOCUMENTATION

---

- Maintain accurate records of journey details, including routes, stops, times, and any incidents or deviations from the plan.

Notes: \_\_\_\_\_

\_\_\_\_\_

\_\_\_\_\_

\_\_\_\_\_

\_\_\_\_\_

\_\_\_\_\_

\_\_\_\_\_



# COMPETENCY 5

## Driving in Adverse Weather

# Driving in Winter Conditions

SUGGESTED TIME:  HRS

Winter driving comes with its own set of challenges due to adverse weather conditions. Proper preparation and defensive driving are essential to ensure the safety on the roads during the winter season. In this section drivers learn how being prepared and adopting safe and defensive driving practices, can minimize the risks associated with winter driving and help to navigate through challenging conditions confidently and safely.

---

## In This Section

Checking the Weather.....	53
Best Practices for Driving in Adverse Weather.....	54
Driving in Adverse Weather Conditions .....	56
Emergency Driving Techniques .....	58
Onboard Training .....	62

*Add important notes here for quick reference.*

---

---

---

---

---

---

---

---

---

---

# Checking the Weather

Visit these websites to stay informed and prepare for adverse conditions, weather warnings, and traffic delays.

- Mentor show trainee the following sites. Scan the QR code with your mobile device or click on the text to visit.*

**FIND:  
WEATHER  
FORECASTS,  
WARNINGS, AND  
ADVISORIES**



**Environment  
Canada**

**VIEW ROAD  
CONDITIONS:  
TRAFFIC SPEEDS,  
SNOW PLOWS,  
CAMERAS,  
INCIDENTS**



**511 Alberta**

**VIEW RADAR  
DATA FOR:  
RAIN, ICE,  
AND SNOW**



**The  
Weather  
Network**

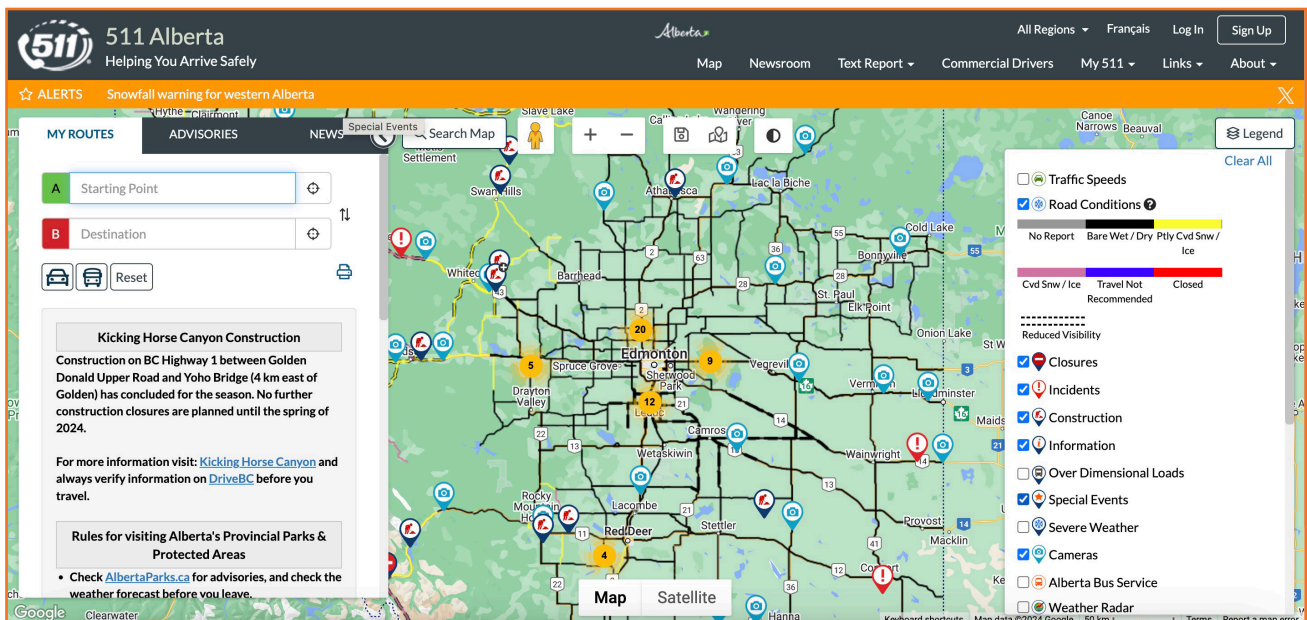

The screenshot shows the 511 Alberta website interface. At the top, there is a navigation bar with the 511 logo, the text "511 Alberta Helping You Arrive Safely", and various menu options like "Map", "Newsroom", "Text Report", "Commercial Drivers", "My 511", "Links", and "About". Below the navigation bar, there is a "MY ROUTES" section with input fields for "Starting Point" and "Destination", and a "Reset" button. A "Kicking Horse Canyon Construction" advisory is displayed, stating that construction on BC Highway 1 has concluded for the season and no further closures are planned until the spring of 2024. The main part of the interface is a map of Alberta showing various road conditions, traffic speeds, and weather data. A legend on the right side of the map lists various features that can be toggled on or off, including Traffic Speeds, Road Conditions, Reduced Visibility, Closures, Incidents, Construction, Information, Over Dimensional Loads, Special Events, Severe Weather, Cameras, Alberta Bus Service, and Weather Radar. The map shows various cities and roads across Alberta, with different colors and icons indicating road conditions and traffic speeds.

# Best Practices for Driving in Adverse Weather

□ *Mentor and trainee, review and discuss best practices for driving in adverse weather.*

## **Arrive Early**

Be prepared for the unexpected to handle delays smoothly.

## **Remember, Communication is Key**

If running late, inform dispatch instead of trying to make up time during pickups or drop-offs.

## **Create A Cushion of Space**

Increase the distance for stopping in adverse weather to enhance safety.

## **Avoid Cruise Control and Engine Brakes**

In adverse weather, maintaining manual control is crucial to prevent skidding and losing control.

## **Don't Use High Beams in Poor Visibility**

Do not use high beams in snow or fog to avoid the "Star Wars effect," which worsens visibility, see an example below.

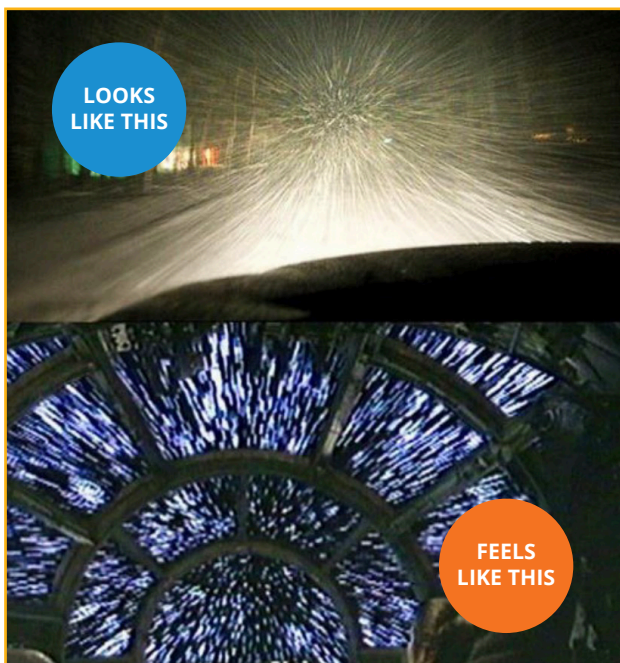

## **Provide Driver Courtesy on Hills**

When encountering other school buses on a hill, the bus descending should yield to the ascending bus due to the difficulty of restarting on a slippery slope.

## **Use Lower Gears for Traction**

Utilize lower gears (1-2-3) to start the bus if wheels are stuck or spinning, and maintain gentle acceleration to prevent traction loss. Lower gears are also recommended for navigating hills.

## **Use Neutral for Slippery Descents**

Use neutral and avoid braking when going down slippery hills to keep the wheels rotating and maintain control. Assess the risk and proceed only if comfortable. (See pg. 55, "Icy Hill Maneuver")

## **Maintain Control in Emergencies**

If losing control and heading into a ditch, straighten the wheels to improve the chance of keeping the bus upright.

## **Adapt Driving to Conditions**

Gravel, debris, poor visibility, valleys, and hills require adjusting speed. In bad weather, allow extra travel time, increase following distance, reduce speed, and maintain a space cushion. Use cruise control only under suitable road surface and traffic conditions.



# Clearing Snow Off the Bus

Snow accumulation on the bus creates several safety issues and must be cleared off the bus before driving—do not expect the wind to clear it off. It is important for the driver to take time to clear the snow off the bus so the bus headlights, clearance lights, school bus signs front and back, and 8-light system front and back are clear of snow and visible. Clearing the snow also helps reduce the blow off the bus once the bus starts driving thus reducing visibility and ‘snow clouds’ for other road users.

---

## Adverse Weather: Videos for Discussion

- Trainee, scan the QR code with your mobile device or click on the text to watch the videos below.*
  
- Mentor and trainee, after watching the “Bus Gets Stuck in Snow” video, discuss the potentially dangerous situations that unfolded including:*
  - How parents or bystanders helping a stuck bus can quickly become a dangerous situations.*
  - The dangers of driving with the doors open.*
  - How a helper pushing on the open doors, rocking the bus, could damage the doors, or the helper could fall under the bus.*
  - The hazards of hands near spinning tires if trying to place cardboard while the wheels are in motion.*
  - How people pushing the bus from behind could slip under or be knocked down.*

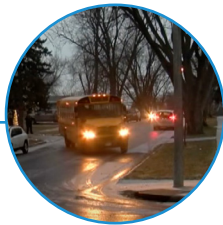

Icy Hill  
Maneuver



Bus Gets  
Stuck in  
Snow



8 Tips for  
Driving  
Safely  
in Bad  
Weather

# Driving in Adverse Weather Conditions

- Mentor and trainee, review and discuss the various adverse conditions and how to respond safely.*
  
  - Mentor, share relevant school division/bus contractor policies and procedures for a driver who feels conditions are too unsafe to continue driving.*
- 

## Fog and Mist

- Avoid using high beams as they reflect off the fog and mist, reducing visibility.
  - Always use your strobe light for increased visibility of the school bus to other road users.
  - When approaching intersections, slow down and stop if required by a traffic control device. If stopped, you may want to cancel fans/noise and open the window to look and listen before proceeding.
  - Slow down and open the window, cancel noise when approaching railway crossings to allow you to look and listen while driving across tracks.
  - If approaching an uncontrolled railway crossing where visibility is poor, secure and shut down the bus, use neutral/park gear, set the park brake, take the keys, and check the tracks on foot.
- 

## Wet Road

Tires may lose contact with the road surface in wet conditions, causing hydroplaning. If this happens, do not brake abruptly. Instead, release the accelerator to slow down and steer in the correct direction.

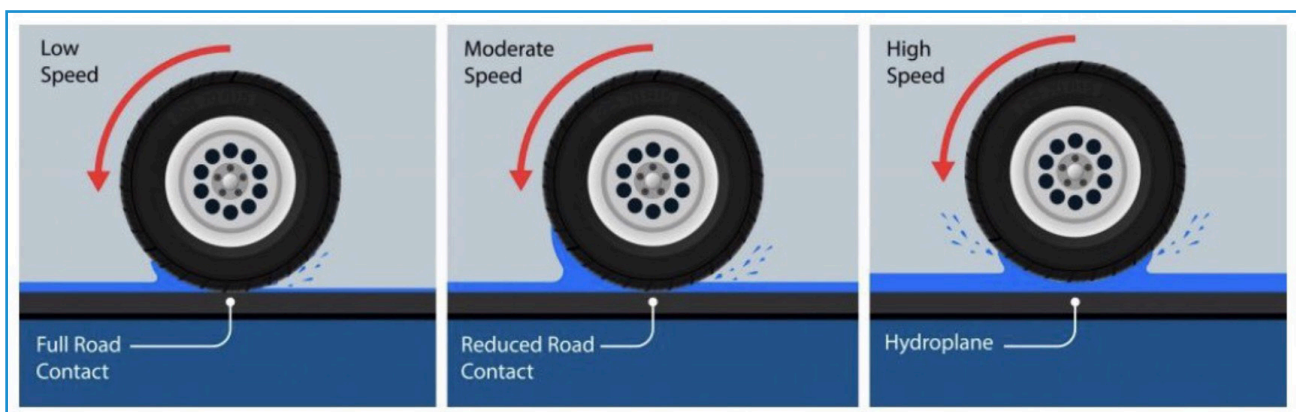

## Gravel Road

- Be aware that changing weather conditions can make gravel roads slippery when wet or muddy. Heavy rainfalls may make the ground extremely muddy and cause the vehicle to become stuck.
  - If unsure about the road condition, safely check the ground outside the bus. If the vehicle is stuck, seek assistance rather than risking further damage by attempting to drive out.
- 

## Ice and Snow

Roads can become very slippery when the temperature rises and snow begins to melt. Avoid using cruise control in such poor weather and road conditions. Black ice, a transparent yet dangerous layer of ice, forms on the roadway, especially under freezing conditions after snowmelt or rain. It is difficult to see and can cause loss of vehicle control. Black ice forms most commonly at night or early morning, particularly in areas without direct sunlight, on bridges, overpasses, and less traveled roads.

### DEALING WITH BLACK ICE

---

- To detect black ice, look for glossy, smooth surfaces that differ from the rest of the pavement, though it's often invisible.
- If you encounter black ice, remain calm, do not hit the brakes, and try to keep the steering wheel straight. Gently steer in the direction if the rear end slides.
- Slow down by decelerating, avoid braking, and if possible, shift into a lower gear for more control. Watch your RPM's and shift down gradually to avoid sudden speed changes.
- Aim for areas of traction if possible, such as textured ice or snow-covered areas.

### PREVENTING OR MINIMIZING FUTURE ENCOUNTERS WITH BLACK ICE

---

- Travel slowly and avoid speeding during icy conditions.
- Keep a safe distance from other vehicles, and ensure your windshield is clear of ice and snow for better visibility.
- Drive with your headlights on to help see any possible sheen from black ice.
- Never use cruise control or engine/exhaust brakes on potentially icy roads.

Notes: \_\_\_\_\_

\_\_\_\_\_

\_\_\_\_\_

# Emergency Driving Techniques

- Mentor and trainee, review and discuss the following techniques for emergency driving situations.*

---

## Skid Control

### Seamless Driving Skills

Expert drivers maneuver their vehicles so smoothly that gear shifts, turns, and braking go unnoticed by passengers. Achieving this requires foresight, vigilant observation, and a reduced speed, particularly on unfamiliar roads.

### Causes of Skids

Skids are often a result of driving too quickly for the conditions, with slippery road surfaces being a common culprit. However, it's essential to recognize that driver mistakes also play a significant role in causing skids. These errors can include overly sharp turns or misjudging a curve.

### Effects of a Skid

During a skid, the vehicle's tires lose their grip on the road surface, compromising the driver's ability to steer, brake, decelerate, or accelerate effectively.

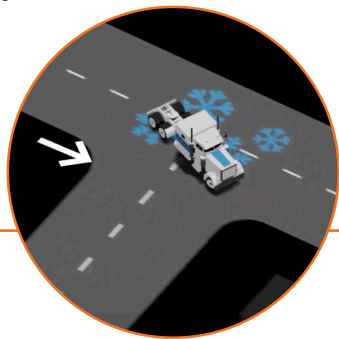

[Skid Control  
and Recovery](#)

### Regaining Control After a Skid

Should a skid occur, it's vital for drivers to quickly notice the loss of traction and effectively regain control. Proper steering and braking techniques are critical for recovery. Recognizing and reacting to the type of skid promptly can prevent accidents and ensure the safety of all road users.

### Types of Skids and Their Causes

- **TIRE FAILURE SKIDS:** These can occur due to under-inflation or the sudden loss of air pressure from a blowout.
- **FRONT WHEEL SKIDS:** Often result from malfunctioning brakes, too much acceleration, or excessive speed on curves, as well as from navigating rough or slick surfaces.
- **HYDROPLANING:** This specific type of skid happens when a vehicle moves too fast over a wet surface, causing the tires to ride on a layer of water.
- **OIL-SLICK SKIDS:** The initial minutes of rain can create an oily film on the road, leading to skid conditions.

- Trainee, scan the QR code with your mobile device or click on the text to learn more about effective skid control.*

## Steering

1. Avoid oversteering; steer in the direction the rear of the vehicle is skidding until traction is regained, then straighten the wheels.
2. Be aware that correcting one skid can lead to another in the opposite direction, often due to overcorrection.
3. If the vehicle fishtails in the opposite direction, adjust your steering to match the new skid direction.
4. Once the wheels are straightened, you will have regained control of the vehicle.

---

## Braking

### Stay Calm

Panic can impair decision-making, staying calm keeps actions to be focused on safety.

### Practice Skid Control

Most people lack the opportunity to properly practice handling skids or loss of control, carve out time to practice before an emergency occurs.

### Learn Threshold Braking

This technique involves applying brake pressure up to the point just before the wheels lock, then adjusting to avoid skidding.

### Differentiate from Pumping Brakes

Threshold braking is often confused with pumping the brakes but involves fine control to prevent the wheels from locking.

### Master Quick Adjustments

Requires quick and constant adjustments to maintain braking right at the edge of skidding without locking the wheels.

---

## Enhancing Visibility in Poor Weather Conditions

### Acknowledge Reduced Visibility

If snow, fog, or rain impair your ability to see other vehicles, it's likely they're also struggling to see the school bus. This mutual difficulty emphasizes the need for heightened caution.

### Utilize Strobe Lights for Visibility

Activate the strobe light on the bus to enhance its visibility to others, a crucial step in ensuring safety during adverse weather conditions.

### Inspect Reflective Tape During Pre-Trip Checks

Before setting off, ensure the reflective tape is intact and not worn out. This tape serves as an additional visibility measure, making the bus more noticeable to others on the road.

# Preparing for Cold Weather

## **Emphasize Appropriate Attire**

Ensure students are dressed suitably for cold weather—setting an example by wearing appropriate clothing is vital.

## **Be Prepared for Emergencies**

In case of mechanical issues, be aware that the bus can cool down quickly. Wearing the right clothing is crucial for your safety and comfort.

## **Consider Outside Duties**

The pre-trip inspection and potential emergency situations may require the bus driver to be outside in various weather conditions. Being properly dressed is essential for these responsibilities.

---

# Navigating Snow-Covered Lanes

## **Stay Alert in Ambiguous Lanes**

Snow-covered lanes can blur the usual markers that designate lane boundaries, leading to confusion and potentially causing vehicles to drift into your lane. Vigilance is key in these conditions.

## **Maintain a 360-Degree Awareness**

It's crucial for drivers to keep a constant watch on their surroundings, especially when navigating turns or curves where lane markers are obscured by snow.

## **Exercise Driver Courtesy**

In conditions where snow covers lane markers, it may be necessary to adjust the driving path of the bus to follow the clearer wheel paths, even if they don't perfectly align with the designated lanes. This approach, when safe, helps prevent spraying snow and gravel on following vehicles.

## **Prioritize Safety**

Always evaluate the safety of adjusting lane position in snow-covered conditions. The goal is to maintain a balance between staying within the lane as much as possible and minimizing the risk to oneself and others on the road.

Notes: \_\_\_\_\_

\_\_\_\_\_

\_\_\_\_\_

\_\_\_\_\_

\_\_\_\_\_

\_\_\_\_\_

\_\_\_\_\_

\_\_\_\_\_



# Managing Winter Fronts for the Bus

## Importance of Keeping the Bus Warm

Just as it's crucial for the driver to stay warm, the bus needs to maintain an optimal temperature for its engine during cold weather. A winter front can significantly aid in keeping the engine warm.

## Switching Screens

Understand the right time to switch from a bug screen to a winter front, if your bus uses these, and know how to properly install the winter front to avoid overheating the engine.

## Adapting to Different Bus Models

Be aware that winter fronts vary across different bus models. Some may not seal completely, and in extreme cold, placing a piece of cardboard inside any gaps can provide extra insulation.

## Monitoring Temperature Changes

The morning might be cold, but as temperatures rise throughout the day, you may need to adjust the winter front or remove any added insulation like cardboard to prevent overheating.

## Regular Checks

Incorporate checking the winter front into your pre- and post-trip routines to ensure it's adjusted according to the day's temperature and to prevent engine overheating.

## Observing Temperature Gauges

Keep an eye on the temperature gauge on the bus. A quick rise in temperature is a clear indicator that you need to open the winter front or vent the engine to cool down, underscoring the importance of monitoring your gauges while driving.

## EXAMPLES OF WINTER FRONTS

---

Familiarize yourself with the various types of winter fronts available for different buses to ensure proper usage and maintenance.



# Onboard Training

- Mentor and trainee, while on the bus, review and practice the following:*

## *PREPARING THE BUS*

- How to secure items in the bus.*
- How to clear snow off the school bus signs, clearance lights, and 8-way lights.*

## *DRIVING IN ADVERSE WEATHER*

- Using lower gears and moving the bus with an easy acceleration so as to not spin the tires.*
- Using neutral to go down a steep hill without using the brakes.*

## *NAVIGATING SNOW-COVERED LANES*

- Lane definition and driving where the lane actually is.*
- When it would be courteous to safely drive where bare wheel paths are that don't line up with the driving lane.*
- Where the correct lane is on turn and corners—watching how the bare wheel paths of an oncoming lane or your lane may cross center line on a corner.*
- Turning the bus around being aware of:*
  - *Snow banks and narrowing of roadways.*
  - *Soft shoulders that may be snow covered.*
  - *Obstacles or hazards that may be snow covered/watching for pedestrians/cyclists.*
  - *Icy roads, grades that may cause the bus to slide.*

## *INSTALLING WINTER FRONTS AND READING GAUGES*

- Installing a winter front on a variety of buses and the various ways to open the front and safely place cardboard if required.*
- Reading temperature gauges in a variety of buses and normal operating temperature versus high temperature.*



## COMPETENCY 6

# Driving in Night/Dark Conditions

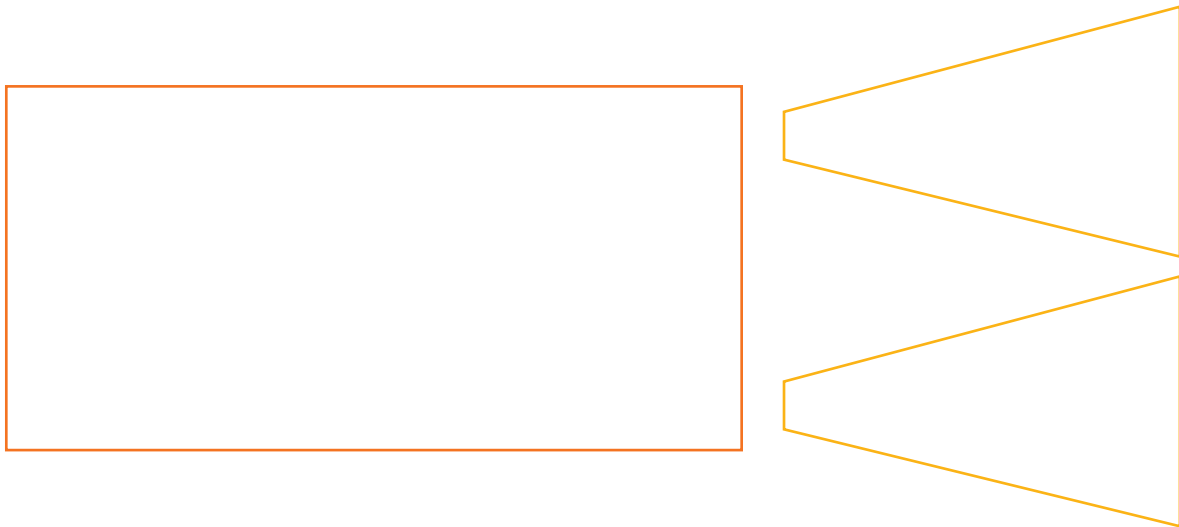



# Preparing to Drive in Night/Dark Conditions

Reduced visibility is the most obvious challenge when driving at night or in low light. Darkness makes it harder to see pedestrians, cyclists, other vehicles, bus stops, road signs, and animals. Not only is visibility harder for the bus driver, but also causes challenges for other road users to see the school bus and students crossing the road at bus stops. To mitigate these challenges, drivers should take precautions when driving at night and in dark conditions.

- Mentor and trainee, review and discuss the following ways to prepare for driving in night/dark conditions.*
- 

## Pre-Trip

Performing a pre-trip inspection on a school bus is crucial for safety before the vehicle is operated. This inspection can be challenging in the dark or under poor lighting conditions, but it remains essential. To facilitate this task in low-light situations, consider the following tips:

### **Preparation is Key**

Arrange necessary items such as a flashlight, paper towels, and a mallet the night before. Place these tools on the driver's seat or near the entrance for easy access, minimizing the difficulty of locating them in the dark.

### **Fluid Level Check**

If fluid containers are transparent, use a flashlight to backlight the container, which can help you discern the fluid levels more clearly.

### **Daylight Double-Check**

After completing your morning route, conduct a second inspection in daylight. This ensures that any issues or leaks that were not visible in the dark are identified and addressed.

### **Mind the Shadows**

Shadows can obscure parts of the bus during your inspection. To avoid missing any potential issues, change your position frequently to view components from various angles.

### **Hands-Free Illumination**

To keep your hands free while checking under the hood, position the flashlight so it illuminates your work area. This allows you to use both hands for tasks such as pulling dipsticks and checking connections.

## Heightened Wildlife Activity During Twilight Hours

The twilight hours of dawn and dusk are known for an increased presence of wildlife. These periods are when animals are most active, heightening the likelihood of encountering them on or near roadways. In conditions of low light, animals can be particularly challenging to spot in advance.

Drivers should practice vigilant scanning of road peripheries for any signs of movement or the distinct glow of animal eyes, caused by the reflection of the vehicle's headlights. This is known as eyeshine and can aid in detecting wildlife presence. The color of eyeshine can differ between species and range from blue and green to red, white, and yellow. Being aware of these visual indicators can significantly enhance a driver's ability to anticipate and safely respond to wildlife on the road.

---

## Impaired Driving Risks in Night and Early Morning

The likelihood of encountering drivers impaired by alcohol or drugs escalates during nighttime and early morning hours. Nighttime roads may be frequented by individuals driving home after social gatherings or parties, while those who attempt to 'sleep off' the effects may still be impaired the following morning. As a bus driver, heightened vigilance is imperative to identify and steer clear of such drivers. Review the school division/bus contractor drug/alcohol policies and understand how to handle situations involving impaired driving.

## The Hazard of Overdriving Headlights

Overdriving headlights occurs when a vehicle's speed creates a stopping distance that extends beyond the area illuminated by the headlights. This practice limits the driver's ability to make a safe stop. Reflective road signs can exacerbate this, creating a false perception of visibility. These signs may lead drivers to mistakenly believe their visible range extends further than it does, resulting in the overdriving of headlights without due caution. Drivers should be mindful to match their speed with the visibility provided by their headlights to ensure safe travel.

---

## Bus Stops in the Dark

Dark conditions can make locating bus stops difficult. Unfortunately, low light and a lack of street lights can make it more difficult to see landmarks and house numbers, and students waiting in dark clothing can all contribute to difficulties navigating bus stops in the dark. When finding bus stops in the dark, watch your surroundings, slow down but don't impede traffic, and use high beams to increase visibility.

When performing turn arounds in the dark, take extra care—using high beams for maximum visibility and if needed, doing a walk around of the bus to check for obstructions. When leaving the bus always follow procedure by securing the bus, placing the bus in neutral, engaging the park brake, and removing and taking the keys with you. Never rely on students at the back of the bus to determine if it is clear and safe to proceed.

## Oncoming Bright Lights

When headlights from oncoming traffic are intense, drivers should adjust their focus toward the lower right-hand side of the roadway. However, attention must be balanced to avoid concentrating too far to the right, which may lead to unintentional steering in that direction and potentially veering off the road.

## School Bus Visibility Equipment

### STROBE LIGHTS

Use of the strobe light helps increase visibility of the school bus for other road users. During every pre trip inspection, check the strobe light is functioning. Use the strobe light in adverse weather (fog, snow, rain) or wherever the school bus requires additional visibility—during night/dark conditions or when in an unsafe road position.

- Mentor and trainee, review and discuss the school division/bus contractor policy for strobe light use.***

### REFLECTIVE TAPE

Reflective tape helps make school buses more visible to other road users. During pre- and post-trip inspections, drivers should be on the look out for any damage to reflective tape and report missing or worn out sections. Drivers should also be checking that the front and back “School Bus” lettering is not missing or worn out. The type and placement of the Reflective Tape is found in the CSA-D-250, in the Commercial Vehicle Safety Regulation.

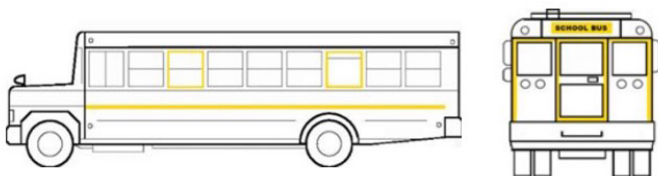

### REFLECTIVE TAPE PLACEMENT

**The school bus must be marked with retro reflective material as follows:**

- (a) on the rear of the body of the bus,
  - (i) 2 parallel horizontal stripes running from the left to the right rear corner of the bus, with the upper strip located above the rear window and the lower strip above the rear bumper, and
  - (ii) 2 parallel vertical strips, one at the left rear corner and one at the right rear corner of the bus, connecting the horizontal strips;
- (b) on each side of the bus,
  - (i) 2 parallel horizontal stripes extending the length of the body of the bus, with the upper strip located above the windows and the lower strip between the rub rails just above the floor line, and
  - (ii) 2 parallel vertical strips, one at the front corner and one at the rear corner of the side of the bus, connecting the horizontal strips.

# Onboard Training

- Mentor and trainee, while on the bus, review and practice the following:*

## **STROBE LIGHTS**

- Review different strobe light switch locations of various buses.*

## **REFLECTIVE TAPE**

- Review the reflective tape and school bus signs, and what to do if they are damaged.*

## **ONCOMING BRIGHT LIGHTS**

- Practice shifting gaze to the right corner of the windshield while maintaining the bus in a straight line. Do this exercise at a slow speed in the yard or in a safe quiet place outside the bus yard.*
- Practice shifting gaze to the right corner of the windshield at medium speed on roadways in town.*
- Practice shifting gaze to the right corner of the windshield at high speed on a primary and secondary highway.*

- Mentor and trainee, while on the bus and during dark conditions, review and practice the following:*

- Watching traffic behind and with a 360 zone of awareness.*
- Responding to back up lights out of driveways and oncoming headlights from side streets.*
- Appropriate use of high beams—not using high beams with approaching traffic within 300 meters.*
- Slowing down without impeding traffic.*
- Looking for any protruding objects around.*
- Conducting safe turn arounds.*



# COMPETENCY 7

## Driving in High Traffic Areas

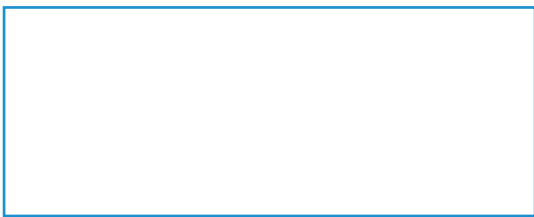
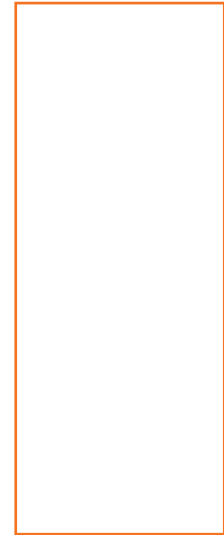

# Driving in High Traffic Areas

SUGGESTED TIME:  HRS

Driving a school bus in high traffic areas can be challenging, but it's a crucial responsibility given the precious cargo on board. Navigating high traffic areas with patience and precision is not only a reflection of driver skill, but also the school division/bus contractor the driver represents. In this section drivers learn how to maneuver busy roadways through turning, merging, and yielding techniques and discuss best practices when encountering emergency vehicles and incidents of road rage.

---

## In This Section

Preparing for Driving in High Traffic Areas .....	71
Common Roadway Encounters .....	73
Speed Management .....	76
Road Rage .....	76
Handling Emergency Vehicles .....	77
Onboard Training .....	78

*Add important notes here for quick reference.*

---

---

---

---

---

---

---

---



# Preparing for Driving in High Traffic Areas

Driving in high traffic areas can be stressful, but being prepared can help. Maintain control and composure by mastering these tools and techniques, ensuring a safe and more enjoyable journey for everyone.

- Mentor and trainee, review and discuss the following ways to prepare for driving in high traffic areas.*

---

## Using Mirrors

Mirrors are a key tool to help bus drivers safely navigate busy roadways. It's important for school bus drivers to recognize and understand how mirrors function and the relationship between mirrors and the zones they cover.

- Trainee, scan the QR code with your mobile device or click on the text to learn about mirror use.*

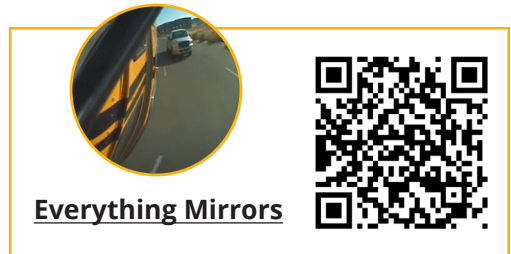

---

## Performing Turns Safely

### TAIL SWING AND OFF-TRACKING

When turning, drivers must consider how the length of the vehicle will impact the turning radius. School buses can have a tail swing, this refers to how much the rear of the bus swings out in the opposite direction of the turn. Buses also experience off-tracking during a turn which causes the back wheels to take a different path than the front wheels. It is important to turning radius as pedestrians and obstructions may be in line of the rear swing or off track of the bus when turning.

- Trainee, scan the QR code with your mobile device or click on the text to learn more.*



## GUIDELINES FOR TURNING SAFELY

### Turning

- Use the hand-over-hand steering method.
- Give the proper signal in advance of the turn.
- Activate turn signals at approximately 30 m in advance of the turn in urban areas.
- Activate turn signals at approximately 100 m in advance of the turn in rural areas.
- Check for clear right of way and traffic signals or signs.
- If stopped, keep brake pedal depressed and front wheels straight. If the bus is pushed forward, it will go in the direction of the tires.
- If the need arises to take space from an oncoming lane, do so only after the turn, not before.

### Left Turns

- Take the left-most lane available on a single-lane turn (unless directed otherwise).
- Take the turn lane to the right (outer) on a dual-lane turn (unless directed otherwise).

*Trainee, scan the QR code with your mobile device or click on the text to learn more about how to turn safely.*



[Safe Turning Procedure](#)

### Right Turns

- Take the right-most lane available on a single-lane turn (unless directed otherwise).
- Take the turn lane to the left (outer) on a dual-lane right turn (unless directed otherwise).

### Completing the Turn

- While turning, check the left and right mirrors for bus body swing and clearance.
- Look well down the driving path, at least one block, continue recovering the steering wheel using hand-over-hand method.
- Check that turn signal has been cancelled once the turn is complete.
- Resume speed and activate right turn signal and move into the right lane as soon as practical, if completing a left turn on a multi-lane road.

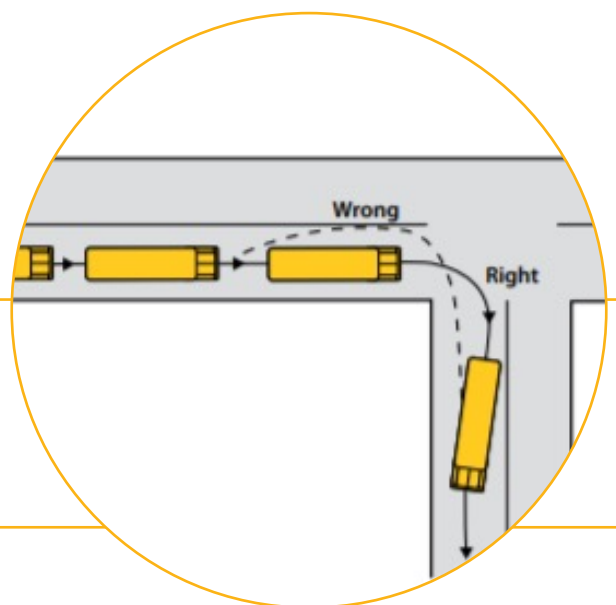

# Common Roadway Encounters

## DRIVING IN TRAFFIC CIRCLES

---

When entering a two-lane traffic circle or roundabout, yield to drivers already in the circle. Drivers entering the circle from the right lane must do so when it is safe and stay in the right lane while in the circle.

- Trainee, scan the QR code with your mobile device or click on the text to learn about signaling and yielding. Then review the steps for driving in a traffic circle.*

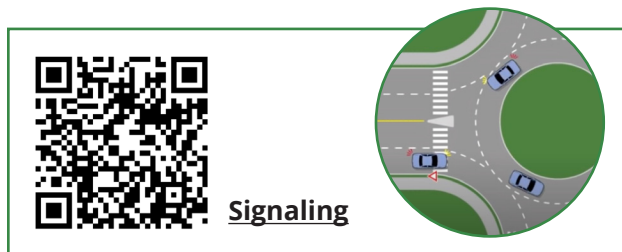

### Steps for driving in a traffic circle:

1. Check for signs prior to entering the traffic circle so that you can be in the appropriate lane.
2. On approach, scan for pedestrians and cyclists at the crosswalks at the entrance and exits of the circle.
3. Yield to traffic in the circle.
4. Activate left signal to communicate if you do not plan to use the first exit.
5. Indicate right signal as you pass the exit preceding your intended exit.
6. Exit the circle.

## RIGHT-OF-WAY AT INTERSECTIONS

---

The Yield sign indicates to drivers that they must yield the right-of-way, slow down or stop if necessary, before entering the intersection or roundabout and must not proceed until it is safe to do so. During a right-of-way situation watch for vehicles who may try to beat the bus to the intersection so they can go first; vehicles who may “roll” the stop sign by not coming to a complete stop; and for cyclists and pedestrians who may have the right of way.

- Trainee, scan the QR code with your mobile device or click on the text to learn more about how to proceed in a right-of-way situation.*

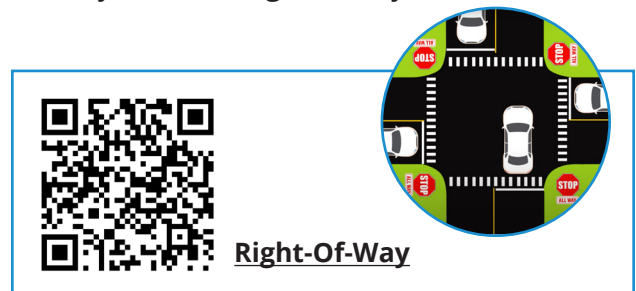

## TRAFFIC LIGHTS

---

When approaching an intersection, note the colour of the traffic light. The light is referred to as a 'fresh green' when it is seen turning green. The light is referred to as a 'stale green' if it was green before it was seen or if it has been green for a while.

### Guidelines for dealing with traffic lights:

- Scan 12-15 seconds ahead in urban areas.
- If the traffic light is fresh, continue within the speed limit, being aware it may turn stale.
- If the traffic light is stale, check the mirrors and cover the brake. The stale light is the first warning that it will soon be changing to amber. Covering the brake reduces reaction time.
- When approaching the traffic light, amber should be treated as "prepare to stop", so covering the brake is a good idea. If the vehicle is already in the intersection (waiting to turn left), amber means "clear the intersection".
- When stopped at a red traffic light, always look left, centre, right, and left again before proceeding. This defensive driving technique will prevent a collision if another driver is running the red light. Keep the wheels in proper position and two hands on the wheel. It is common for drivers to proceed through an intersection when a traffic light has turned to amber instead of slowing or preparing to stop, however this behaviour is discouraged.

*Trainee, scan the QR code with your mobile device or click on the text to learn more about how to proceed safely through traffic lights.*



[Traffic Lights](#)



Notes: \_\_\_\_\_

\_\_\_\_\_

\_\_\_\_\_

\_\_\_\_\_

\_\_\_\_\_

\_\_\_\_\_

\_\_\_\_\_

\_\_\_\_\_

\_\_\_\_\_

## MERGE LANES

---

When entering highways, freeways, and restricted access roads, signal intent and use mirrors and direct view to ensure the path is clear in the right lane. Keep glancing at the gap you chose to enter while making the necessary speed and timing adjustments to safely merge into traffic.

### **Guidelines for merging safely:**

- Plan ahead.
- Be in the proper lane well before reaching the exit.
- Avoid reducing speed abruptly or stopping when merging.
- Use turn signal well in advance of the entrance or exit to alert other drivers.

When it is safe and legal to merge, move into the gap after clearing the solid white line of the acceleration lane.

## WEAVE LANES

---

A weave lane is a short section of road where entrance and exit ramps are closely spaced and vehicles entering and exiting share the same lane. These stretches of road can be particularly perilous if not handled correctly.

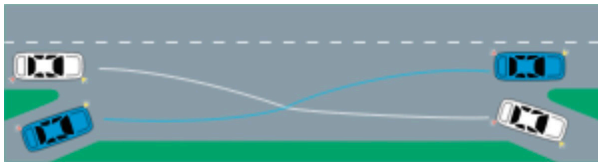

### **Guidelines to ensure a safe and smooth transition when weaving:**

- Adjust speed to match the flow of traffic on the highway to help facilitate a smooth merge when entering and to allow a safe exit when leaving. Unless presented with a yield sign, slow down and yield to vehicles exiting. Always obey traffic rules.
- Check for traffic gaps to try to merge or exit seamlessly without disrupting the flow of traffic.
- Use turn signals to show your intentions and look for other vehicles signals.
- Be aware of other drivers and pay attention to better anticipate their movements and be prepared to adjust your speed or position.
- Maintain a safe following distance and be mindful of vehicles slowing down to exit as you increase speed to merge.

Notes: \_\_\_\_\_

\_\_\_\_\_

\_\_\_\_\_

# Speed Management

Speed management is a major responsibility of a professional driver. It is the responsibility of the driver to know the speed limit of the roadway and for the driver to adjust the speed of the vehicle according to the amount of traffic, mechanical condition of the vehicle, prevailing atmospheric condition, as well as nature and use of the road. A driver's ability to steer safely around curves or objects in the roadways can be reduced by speeding. In addition to the inability to have proper control of the vehicle, speeding also extends the distance necessary to slow down or stop a vehicle in the event of a dangerous situation. The faster the speed, the less time there is to react to situations around you. Adjust your speed to maintain a safe following distance in any road, weather or traffic condition.

---

## Road Rage

As motorists, we have almost all found ourselves in unpleasant situations involving abusive gestures or language from another driver who takes issue with how we drive. Anxiety and frustration can quickly provoke an aggressive or careless driver, who tailgates, speeds, or fails to yield the right-of-way, among other behaviours. Aggressive driving behaviour may lead to incidents of road rage where motorists have been threatened and/or subject to retaliatory actions by angry motorists.

### **Guidelines for avoiding and handling situations of road rage:**

- Make a conscious decision not to take your problems with you when driving.
- Combat the warning signs of stress by getting fresh air and breathing deeply and slowly.
- Drive in a courteous and considerate manner.
- Give way at busy intersections and where traffic lanes merge.
- Do not compete or retaliate. If someone's driving annoys you, do not try to "educate them". Merely continue driving on your route and leave traffic enforcement to the police.
- Do not take other driver's mistakes personally.
- If being followed radio dispatch and do not take the bus home, or to the bus yard if no one is around. Stay in a populated area or drive to the nearest police station.
- If someone comes up to your bus, keep your doors closed and motion them to the drivers side window to talk. Never let someone on your bus even if they seem calm as situations can escalate.

# Handling Emergency Vehicles

When driving around emergency vehicles, it's important to prioritize safety and follow the rules of the road to ensure the well-being of everyone involved.

## Guidelines for encountering emergency vehicles:

- Remain calm and focused and be aware of your surroundings at all times. The importance of the 360 zone of awareness so you can see or hear sirens before and act with time instead of being caught by surprise.
- Pull over to the right side of the road using your turn signal and do not block intersections.
- Stop completely. Do not drive slower off to the side. Come to a complete stop until the emergency vehicle has safely passed. Do not proceed until safe to do so. Do not assume that there is only one emergency vehicle as there may be others coming behind or from other directions. Check in all directions and look in all mirrors and signal and should check before re entering the roadway.
- Leave a clear path for emergency vehicles and do not tailgate or attempt to follow closely behind emergency vehicles.
- Obey traffic signals and signs. If you are at an intersection, follow the normal rules unless directed otherwise by a traffic officer or the emergency vehicles signals. Do not enter an intersection unless you can clear it completely before the emergency vehicle arrives. If you are already in an intersection, proceed to clear it safely before pulling over and stopping until the emergency vehicle has passed.

Remember that yielding the right-of-way to emergency vehicles is not just a legal requirement, but is crucial for the safety of those in need and the emergency responders. It is also important that the safety of those on your bus not be jeopardized by maneuvering the bus in an unsafe manner or positioning the bus in an unsafe road position (too close to train tracks, crossing the centre line etc.). Always prioritize safety and act responsibly on the road.

- Trainee, scan the QR code with your mobile device or click on the text to learn more about handling emergency vehicles.*



[Emergency Vehicles and the Rules of the Road](#)



# Onboard Training

- Mentor and trainee, while on the bus, review and practice the following:*
  - How to adjust and check mirrors on different buses.*
  - Using a safe area to demonstrate a tail swing to see how far the back of the bus swings out.*
  - Safe turns on various roads and performing left and right turns looking at tail swing and off-tracking and following proper turning procedures.*
  - If available, safely maneuver a traffic circle/roundabout.*
  - Merging, yielding, and weave lanes.*
  - Safely respond to traffic lights, intersections, and right-of-ways.*
  - Mock emergency, pulling the bus over, and re-entering the road.*

Notes: \_\_\_\_\_

\_\_\_\_\_

\_\_\_\_\_

\_\_\_\_\_

\_\_\_\_\_

\_\_\_\_\_

\_\_\_\_\_

\_\_\_\_\_

\_\_\_\_\_

\_\_\_\_\_

\_\_\_\_\_

\_\_\_\_\_

\_\_\_\_\_

\_\_\_\_\_

\_\_\_\_\_

\_\_\_\_\_

\_\_\_\_\_

\_\_\_\_\_

\_\_\_\_\_

\_\_\_\_\_

\_\_\_\_\_

\_\_\_\_\_



# COMPETENCY 8

# Route Hazard

# Assessments

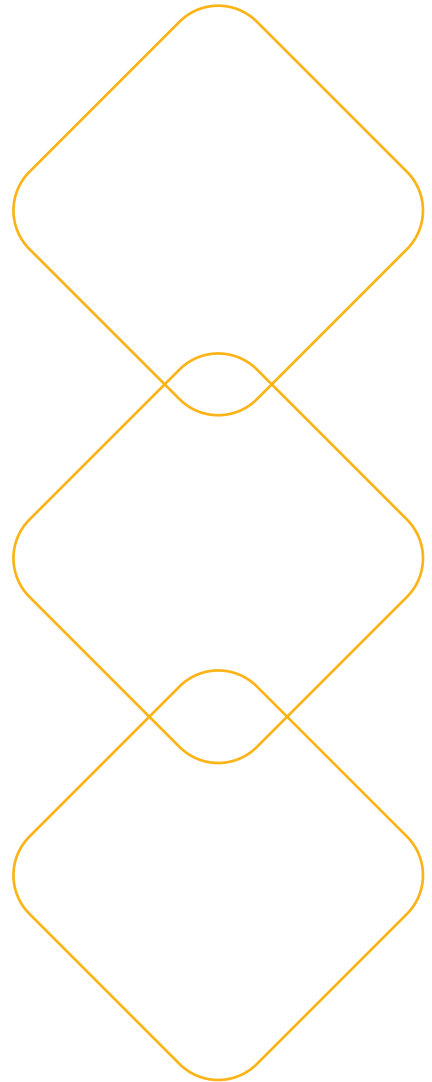

# Route Hazard Assessments

SUGGESTED TIME:  HRS

Route hazard assessments help drivers identify risk along their bus routes. Construction, trees, animals, railway crossings, intersections, can all create risk along a bus route. While drivers may not be able to eliminate all risk along their bus route, they can be aware of it, and/or bring it to their supervisor’s or route planner’s attention. In this section drivers learn how to properly assess for hazards and practice filling in and filing associated reports, forms, and agreements.

---

## In This Section

Performing Hazard Route Assessments .....	81
Park Out Agreement .....	83
Hazard Assessment.....	85
Driver Meetings with Senior Planners .....	86

*Add important notes here for quick reference.*

---

---

---

---

---

---

---

---

---

---

# Performing Hazard Route Assessments

Regular assessments contribute to the overall safety and reliability of student transportation services. Incorporating route assessments into ongoing planning and maintenance processes, ensures changes, safety concerns, and other factors that may impact the effectiveness of school bus routes can be proactively addressed.

- *Mentor and trainee, scan the QR code with your mobile device or click on the text to watch a video about common hazards, then review and discuss the following ways to prepare for and perform a hazard route assessment.*



[Everyday Hazards for School Bus Drivers](#)



## Ways to prepare for and perform a hazard route assessment:

### Route Planning

- Evaluate the chosen route for the most efficient and safe path.
- Consider factors such as traffic patterns, road conditions, and construction zones.
- Choose routes that minimize travel time and avoid potential hazards.

### Stops and Pick-Up/Drop-Off Points

- Review the locations of bus stops to ensure they are safe and easily accessible for students.
- Confirm that each stop allows for proper visibility and space for the bus to maneuver.
- Consider the proximity of stops to students' homes and the overall convenience for families.

### Safety Measures

- Ensure that the route adheres to all traffic laws and regulations.
- Identify potential safety hazards such as busy intersections, blind spots, or areas with high pedestrian traffic.
- Confirm that bus stops and pick-up/drop-off points are in well-lit areas.

### Communication

- Establish effective communication channels with parents, school staff, and transportation coordinators.
- Provide clear instructions for students and parents regarding bus stop locations and pick-up drop-off times.
- Develop a protocol for notifying parents and the school in case of delays or changes to the route.

## Emergency Preparedness

- Develop and communicate emergency procedures to the bus driver.
- Ensure that the driver is familiar with the location of emergency services along the route.
- Have a contingency plan for unexpected events such as road closures or severe weather conditions.

## Driver Training

- Ensure that the bus driver is adequately trained on the specific route.
- Familiarize the driver with the locations of all stops, potential challenges, and emergency procedures.
- Conduct periodic refresher training to keep the driver updated on any changes to the route or procedures.

*Trainee, scan the QR code with your mobile device or click on the text to access sample route forms.*

## Vehicle Maintenance

- Regularly inspect and maintain the school bus to ensure it is in good working condition.
- Conduct pre-trip inspections to identify any issues before starting the route.
- Address any maintenance concerns promptly to prevent breakdowns during the route.

## Monitoring and Evaluation

- Implement a system for monitoring the bus route, such as GPS tracking or regular check-ins with the driver.
- Gather feedback from the driver, students, parents, and school staff to identify areas for improvement.
- Conduct periodic assessments to ensure ongoing compliance with safety and efficiency standards.



The image shows a sample of a 'Route Assessment Form' from the Government of Alberta. The form is titled 'ASSESSMENT CHECKLIST' and includes fields for 'School Authority', 'Date', and 'Route being assessed'. It contains a detailed paragraph about the assessment's purpose and a section for 'Assessment conducted by' with checkboxes for 'Bus Operator', 'Transportation Staff', and 'Other'. Below this is a section for 'Reviewed by' with fields for name and position. A QR code is located at the bottom left of the form, and the text 'Route Assessment Form' is at the bottom right.



The image shows a sample of a 'Route Amendment Form'. The form is titled 'ROUTE AMENDMENT FORM' and includes fields for 'Name', 'Date', 'Address', 'Phone', 'Parent Contact', and 'Driver's Initial'. It also has a section for 'For Office Use Only' with fields for 'Completed' and 'Date'. A QR code is located at the bottom left of the form, and the text 'Route Amendment Form' is at the bottom right.

# Park Out Agreement

A park out agreement for school bus drivers typically refers to an arrangement where school buses are parked or stored at a specific location when not in use. This agreement outlines the terms and conditions under which the buses are parked, including considerations such as location, maintenance, and security. Before finalizing a park out agreement, it's advisable to consult with all relevant stakeholders, including school division officials and transportation department representatives, to address the specific needs and concerns of the school bus drivers and the organization.

## **Key elements that might be included in a park out agreement for school bus drivers are:**

### **Parking Location**

- Clearly specify the designated parking location for the school buses during non-operational hours.
- Outline any restrictions or conditions related to the parking facility, such as available space, access hours, and any shared usage with other vehicles.

### **Security Measures**

- Address security concerns by detailing any security measures in place at the parking location.
- Consider factors such as lighting, fencing, surveillance cameras, and security personnel to ensure the safety of the parked buses.

### **Maintenance Facilities**

- Specify whether there are on-site maintenance facilities or if maintenance activities will be conducted elsewhere.
- Outline any provisions for routine maintenance, inspections, and repairs that may take place during the parked hours.

### **Access and Entry Protocols:**

- Define protocols for bus drivers to enter and exit the parking facility.
- Address any key or access card requirements and procedures for ensuring that only authorized personnel have access to the parked buses if required.

### **Hours of Operation:**

- Clearly state the hours during which buses are permitted to be parked at the designated location.
- Consider whether the agreement allows for extended parking during weekends, holidays, or school breaks.

### **Compliance with Regulations:**

- Ensure that the park out agreement complies with local regulations and zoning requirements.
- Include provisions for adhering to any environmental or safety regulations related to the parking of school buses.

## Responsibilities of Parties:

- Clearly define the responsibilities of both the school division or transportation department and the entity providing the parking space.
- Specify any maintenance responsibilities, costs associated with parking, and any shared duties related to security.

## Term of Agreement:

- Establish the duration of the park out agreement, including the start and end dates.
- Include provisions for renewal or termination of the agreement with advance notice.

- Outline insurance requirements for both parties to cover potential damages, accidents, or other liabilities.
- Specify the types and amounts of insurance coverage necessary for compliance with the agreement.

## Costs and Fees:

- Detail any costs or fees associated with parking the buses at the designated location.
- Include payment terms and conditions, such as frequency of payments and any penalties for late payments.

*Trainee, scan the QR code with your mobile device or click on the text to access sample park out contract forms.*

## Insurance and Liability:



**Sample Park Out Agreement**

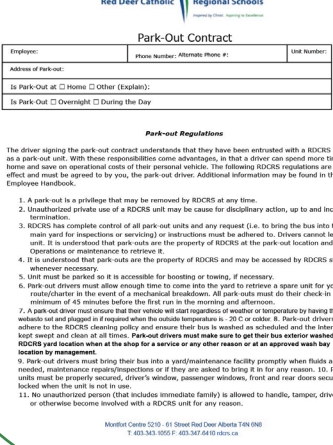

Notes: \_\_\_\_\_

\_\_\_\_\_

\_\_\_\_\_

# Hazard Assessment

Completing a hazard assessment for school bus drivers is a proactive and comprehensive approach to ensuring the safety of everyone involved in school transportation. It helps in identifying, mitigating, and managing risks to create a safer and more secure environment for students and drivers alike.

**Key reasons why conducting a hazard assessment is important are:**

## **Risk Identification**

A hazard assessment helps identify potential risks and hazards associated with the school bus driver's tasks and responsibilities. This includes risks related to the vehicle, the route, student behaviour, and external factors.

## **Prevention of Accidents and Injuries**

By proactively identifying and addressing hazards, the risk of accidents and injuries can be significantly reduced. This is crucial given the responsibility of transporting students, who are a vulnerable population.

## **Compliance with Regulations**

Many jurisdictions have regulations and standards that require employers, including school divisions, to conduct hazard assessments to ensure workplace safety. Compliance with these regulations is essential to avoid legal issues and penalties.

## **Customization to Specific Routes**

Hazard assessments can be tailored to specific bus routes and the unique challenges they present. Factors such as traffic conditions, road types, weather patterns, and geographic features can vary, requiring specific considerations for each route.

## **Driver Training and Awareness**

The hazard assessment process allows for the identification of potential risks that may not be immediately apparent. This information can be used to enhance driver training programs, ensuring that drivers are well-prepared to handle various situations.

## **Emergency Preparedness**

Identifying potential hazards aids in developing effective emergency response plans. Whether it's a mechanical issue with the bus, inclement weather, or other unforeseen events, having a comprehensive hazard assessment helps in preparing for emergencies.

## **Continuous Improvement**

Hazard assessments are not static documents. They should be regularly reviewed and updated to account for changes in routes, regulations, and other factors. This commitment to continuous improvement ensures that safety measures remain effective over time.

## Enhanced Communication

The hazard assessment process promotes communication and collaboration between school bus drivers, transportation coordinators, and safety personnel. This ensures that all stakeholders are aware of potential risks and can work together to address them.

## Reduced Liability

A well-documented hazard assessment can be crucial in the event of an incident. It demonstrates that the school division has taken reasonable steps to identify and mitigate risks, potentially reducing liability in the case of accidents or injuries.

## Driver Well-being

Considering the well-being of school bus drivers is essential. A hazard assessment can identify factors that may contribute to driver stress or fatigue, allowing for adjustments in scheduling or other measures to support the mental and physical health of drivers.

*Trainee, scan the QR code with your mobile device or click on the text to access sample hazard assessment.*



[Sample Hazard Assessment](#)

WWORKS Hazard Assessment (Bus Driver)										
School/Worker:	Various Transportation Bus Driver	Job/Position Summary:	Transport students.				Assessment Team:	Kelli Pickett		
Step 1 List Types of Work and Work-Related Activities (1)		Step 2 Identify Existing or Potential Hazard Sources/Types (2)		Step 3 Assess Risk and Prioritize the Hazards			Identify and Implement			
Type of Work	Related Tasks / Activities	Environmental / Tools / Equipment / People	Hazard Type: Ergonomic, Biological, Psychological, Physical, Chemical	Prevalence of Exposure (6)	Severity of Potential Injury (7)	Control Measures (8)	Risk Level (9)	Summary of Recommended Hazard Controls: Engineering Controls (1) Administrative Controls (4) Personal Protective Equipment (5)		
Pre Trip Inspection	1. Opening the hood of the bus	1. Potential fall from standing on tire weights/heavy causing injury		4	3	3	36	High	1. Ensure 3 point contact with bus. Do not over extend.	
	2. Check fluid levels	2. Potential fall from standing on the nothing to hold on to while checking		4	3	1	12	Med	2. Provide training the new drivers on proper procedures for checking fluids. Ensure 3 point contact with bus. Do not over extend.	
	3. Closing the hood of the bus	3. Weight/heavy causing injury		4	4	1	16	Med	3. Adjust hood springs so it does not spring open or drop down to close. Do not over extend.	
	4. Walk around the bus to inspect	4. Slips/trips/falls		4	4	3	48	High	4. Provide drivers with safe walking information on route and line. Ensure parking areas are well lit and marked when necessary. Ensure proper footwear is worn.	
	5. Entering the bus			4	3	3	36	High	5. Ensure seat belts are available.	

## COMPETENCY 8: ACTIVITY

# Driver Meetings with Senior Planners

It is a benefit for both the planner and the driver for drivers to meet with the person responsible for route planning. The driver may not understand why the bus is routed as it is, and the planner may not understand the day-to-day traffic activity along the route. Getting together ensures that the route is driven and planned in consideration of student safety, route efficiency and budgetary restraints.

*Mentor assist Trainee to arrange a meeting with Senior Planners*



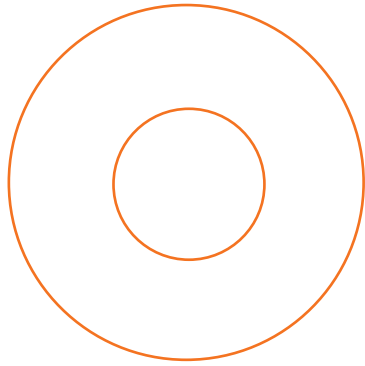

## COMPETENCY 9

# Collision Avoidance and Emergencies

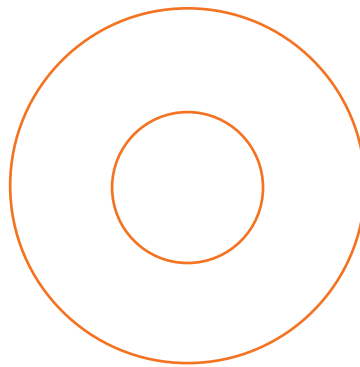



# Collision Prevention & Emergency Maneuvers

School bus collision prevention is a critical aspect of ensuring the safety of students and everyone on the road. There are several strategies and measures to help reduce the risk of collisions involving school buses and enhance the overall safety of student transportation. Regular training, communication, and technology integration play key roles in achieving this.

- Mentor and trainee, review and discuss the following ways strategies and measures for collision prevention.*

## **Driver Training and Certification**

Ensure that school bus drivers undergo thorough training and certification programs. Drivers should be well-versed in safe driving practices, defensive driving techniques, and handling emergency situations.

## **Regular Driver Evaluations**

Conduct regular evaluations of school bus drivers to assess their driving skills and adherence to safety protocols. Identify areas for improvement and provide additional training when necessary.

## **Vehicle Maintenance**

Implement a rigorous maintenance schedule for school buses to ensure that they are in optimal working condition. Regular inspections should include brakes, tires, lights, and other critical components.

## **Use of Technology**

Equip school buses with safety technologies such as collision avoidance systems, blind-spot detection, and backup cameras. These technologies can help alert drivers to potential hazards and reduce the risk of collisions.

## **Speed Management**

Emphasize and enforce appropriate speed limits for school buses. Encourage drivers to adhere to posted speed limits, especially in school zones and residential areas.

## **Proper Loading and Unloading Procedures**

Establish and enforce strict loading and unloading procedures to ensure the safety of students. Drivers should use designated loading zones and wait until all students are seated before moving the bus.

## **Maintain Safe Distances**

Instruct drivers to maintain a safe following distance from other vehicles. This allows for better reaction time in case of sudden stops or emergencies.

## **Route Planning and Assessment**

Regularly assess and update school bus routes to account for changes in traffic patterns, construction zones, and other factors. Ensure that routes are designed to minimize potential hazards.

## Weather Preparedness

Train drivers to adjust their driving behaviour based on weather conditions. In adverse weather, such as rain or snow, drivers should exercise additional caution, reduce speed, and be prepared for longer stopping distances.

## Communication with Other Drivers

Encourage clear communication between school bus drivers and other motorists on the road. Use signals, lights, and proper signage to indicate stops, turns, and other maneuvers.

## Emergency Response Training

Provide drivers with comprehensive training on emergency response procedures. This includes protocols for handling breakdowns, accidents, and other unexpected events.

## Community Education

Educate the community, parents, and

students about the importance of safe behaviour around school buses. Raise awareness about the dangers of passing stopped school buses and the need to exercise caution in school zones.

## Enforcement of Traffic Laws

Collaborate with law enforcement agencies to enforce traffic laws related to school bus safety. This includes strict penalties for passing a stopped school bus and other violations.

## Data Analysis and Monitoring

Utilize data from GPS systems and other monitoring tools to analyze driving patterns, identify areas of concern, and take proactive measures to address potential issues.

We need to add information on using a fire extinguisher.

---

# Emergency Equipment

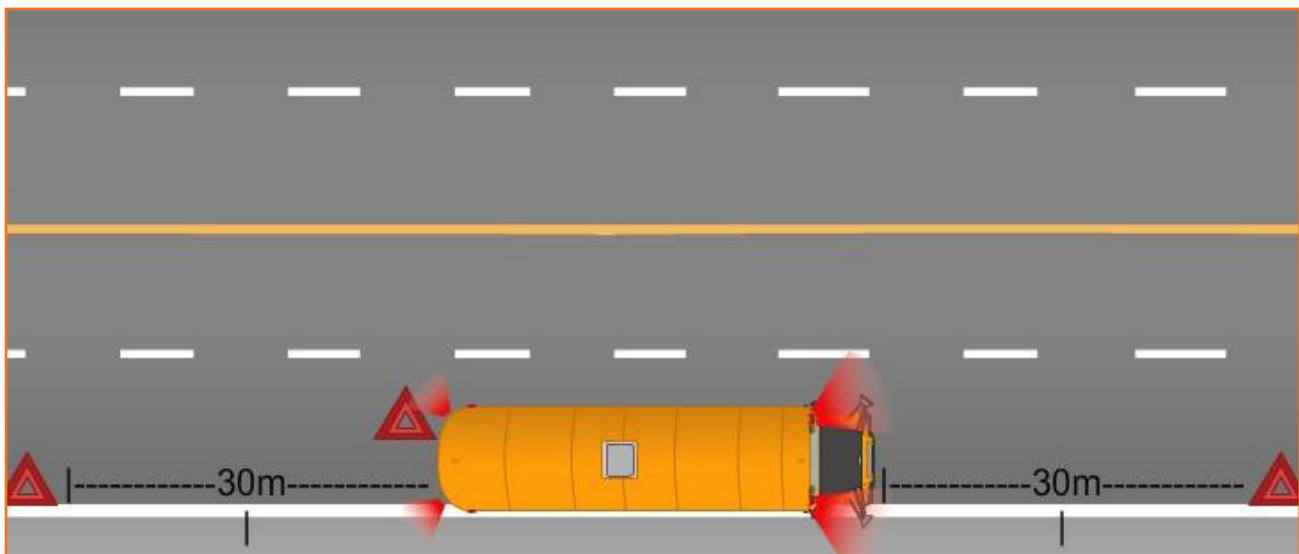

## Advanced Warning Triangles

In the event of a collision or breakdown, bus drivers are required to place warning triangles to mark and protect the scene. These triangles serve to alert other drivers to a problem or collision ahead, assisting in the prevention of further issues at the scene. The strategic placement of these warning devices is critical, as they offer a caution to drivers approaching from both directions, thereby allowing ample time for them to slow down and execute any necessary lane changes.

### Standard Placement Procedure

- Position one warning device approximately 30 metres (100 feet) behind the bus.
- Place another device approximately 30 metres (100 feet) in front of the bus for oncoming traffic.
- Set a third device three metres from the rear of the bus, enhancing rearward visibility.

### Adjusted Placement for Limited Visibility

- If visibility drops to 150 metres or less, place warning devices 75 metres in front of and behind the bus to ensure they are effective under these conditions.

## Fire Extinguisher Operation

Bus drivers may encounter different types of fire extinguisher, but they are all generally operated the same way.

### General procedure for most extinguishers:

1. Remove it from the bracket.
2. Pull the safety pin, breaking the tamper seal.
3. Approach the fire from upwind if possible.
4. Hold the extinguisher in an upright position.
5. Point the discharge apparatus (hose, horn, and nozzle) at the base of the fire, approximately two to three metres (six to eight feet) away.
6. If possible, do not allow the flames to come between you and the exit.
7. Squeeze the handle.
8. Continue to use until fire is out and extinguisher is fully discharged.
9. Even when the fire appears out, do not turn your back on it. Keep watch for flashback until the area on fire has completely cooled.

### When using a fire extinguisher remember the acronym PASS:



**P**ull the pin and point the nozzle away from you.



**A**im low and direct the extinguisher at the base of the fire.



**S**queeze the handle slowly and evenly. Continue to squeeze until the fire is out or extinguisher is empty.

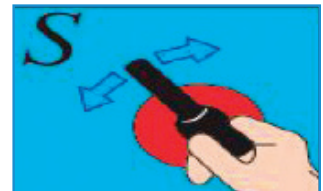

**S**weep the extinguisher from side-to-side. Start at one side of the fire and slowly work to the other side. Do not start in the middle of the fire.

# Safety Resources

□ *Trainee, scan the QR code with your mobile device or click on the text to learn more about safety techniques, emergency equipment, and collision prevention tactics.*



[Side Door Bus Evacuation](#)



[Bus Evacuation and Safety Training Video](#)



[Safety Solutions: Turns and Tail Swings](#)



[Safety Solutions: Distracted Driving](#)



[How to Use a Fire Extinguisher](#)



[Railway Crossing Accident](#)



[Safe Braking Practices and Techniques for School Bus Drivers](#)

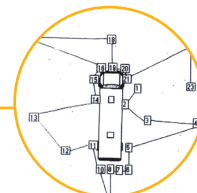

[Mirror Clinic](#)

# Onboard Training

- Mentor and Trainee, while on bus, review and practice the following:*
  - Transferring students during a breakdown or emergency.*
  - A bus evacuation.*
  - Location of and proper use of a fire extinguisher.*
  - Basic emergency procedure—refresh the points out of Mod 9 and 4. For breakdowns use Mod 4 interaction for mechanical breakdown and follow school division/bus contractor policy.*
  - A lock-down situation at a school. Review Hour Zero protocol and talking points as per school division/bus contractor policy.*
  - Student issues on buses. For example a student is injured on bus. Role play calling 911 and follow school division/bus contractor policies and procedures.*



**STAA**

STUDENT TRANSPORTATION ASSOCIATION OF ALBERTA

[staa.ab.ca](http://staa.ab.ca)